



Fine
Woodworking

WOODWORKS PROJECT PLANNER: 2016-2017 ADVANCED PROJECT TOOL BOX



As your woodworking skills grow, so will the list of tools you will be using. Minwax® and Fine Woodworking have teamed up to bring you a great solution to help keep all of your prized tools organized. With expert plans from Fine Woodworking, you can learn how to make this gorgeous dovetailed tool carrier. This classic tool carrier is extremely comfortable to hold and has two removable trays with plenty of room to hold your favorite, go-to tools. The dovetailed sides will allow you to learn a more advanced woodworking technique that you can use for years to come. Once you finish building your tool box, Minwax® will give you tips and techniques on how to add beautiful color by applying a stain and using a clear protective finish to preserve your tool box for years to come!

TOOLS REQUIRED

Hand Tools

- Marking gauge
- Mallet
- Block plane
- Adjustable square
- Sharp chisels
- Hand saw for dovetails
- Sliding T bevel square
- Coping saw

Power Tools

- Table saw
- Miter saw
- Router
- Drill
- Orbital sander
- Band saw/jig saw

Miscellaneous

- Woodworkers vise
- 1/2" forstner bit
- 1/4" straight router bit
- Tenoning jig
- Tape measure
- Sharp knife
- Pencil
- Wood glue
- Assorted clamps
- Safety glasses
- Straight edge
- Wood rasp or file
- Sanding block
- Sandpaper (various grits)
- Gloves for finishing
- Good quality natural bristle brush
- Mineral spirits
(cleanup for oil based products)
- Clean lint free cloths
- Respirator

SHOPPING LIST

Recommended Wood: Pine

Material	Quantity
1/2" Plywood for Case bottom	approximately 2 1/2 sq ft
1 x 12" Pine	10'
1 1/2" x 3" Pine	7'
3/8" x 4" Pine	8'
3/8" x 6" Pine	2'
1/4" Plywood for tray bottoms	
Miscellaneous Pine for cleats, chisel holder etc.	
Wooden Knobs	4

OTHER MATERIALS

- 1 1/4" Screws to attach Buttresses
- Screws for knobs

CUTTING LIST

Component/parts	Quantity	Thickness	Rough Thickness	Width	Length	Material	Board ft
Carcase							
Base	1	1/2"	1/2"	11"	24 1/2"	Plywood	0.9
Sides	2	3/4"	1"	11 1/2"	25 1/2"	Pine	4.1
Ends	2	3/4"	1"	21 1/2"	12"	Pine	3.6
Handle	1	1 1/4"	1 1/2"	3	28"	Pine	0.9
Tray Rest	1	3/4"	1"	7/8"	11"	Pine	0.1
Supporting Parts							
Buttress	2	1 1/4"	1 1/2"	1 1/4"	21 3/8"	Pine	0.6
Chisel Holder	1	3/4"	1"	2"	11 1/4"	Pine	0.2
Cleat	1	3/4"	1"	3/4"	10 1/2"	Pine	0.1
Trays							
Bottom	2	1/4"	1/4"	4 3/4"	21 1/2"	Plywood	0.4
Sides	4	3/8"	1"	4"	22"	Pine	2.4
Ends	4	3/8"	1"	5 11/16"	5 1/4"	Pine	0.8
Dividers	4	1/4"	1"	3 5/8"	4 3/4"	Pine	0.5

Total board feet 14.4

WOOD FINISHING PRODUCTS

Prep: Minwax® Pre-Stain Wood Conditioner (oil-based)
 Stain: Minwax® Wood Finish™, Early American
 Finish: Minwax® Helmsman® Spar Urethane, Semi-Gloss

BEFORE YOU BEGIN

Good craftsmanship begins and ends with good work habits, so make the following steps part of your routine workshop practice. If you have any doubts or questions about how to proceed with a project, always discuss them with your shop instructor.

- Carefully and fully review plans and instructions before putting a tool to the project lumber.
- Work sensibly and safely. Wear safety goggles. Wear the appropriate respirator whenever making sawdust or working with thinners or other solvents.
- At the end of every work session, clean up your shop area and put away all portable tools.

DOVETAILED TOOLBOX

This tool case is strong, comfortable, with plenty of room for hand tools. The two trays lift out for access to the open (non-partitioned) lower section for larger tools such as saws and jointer planes.

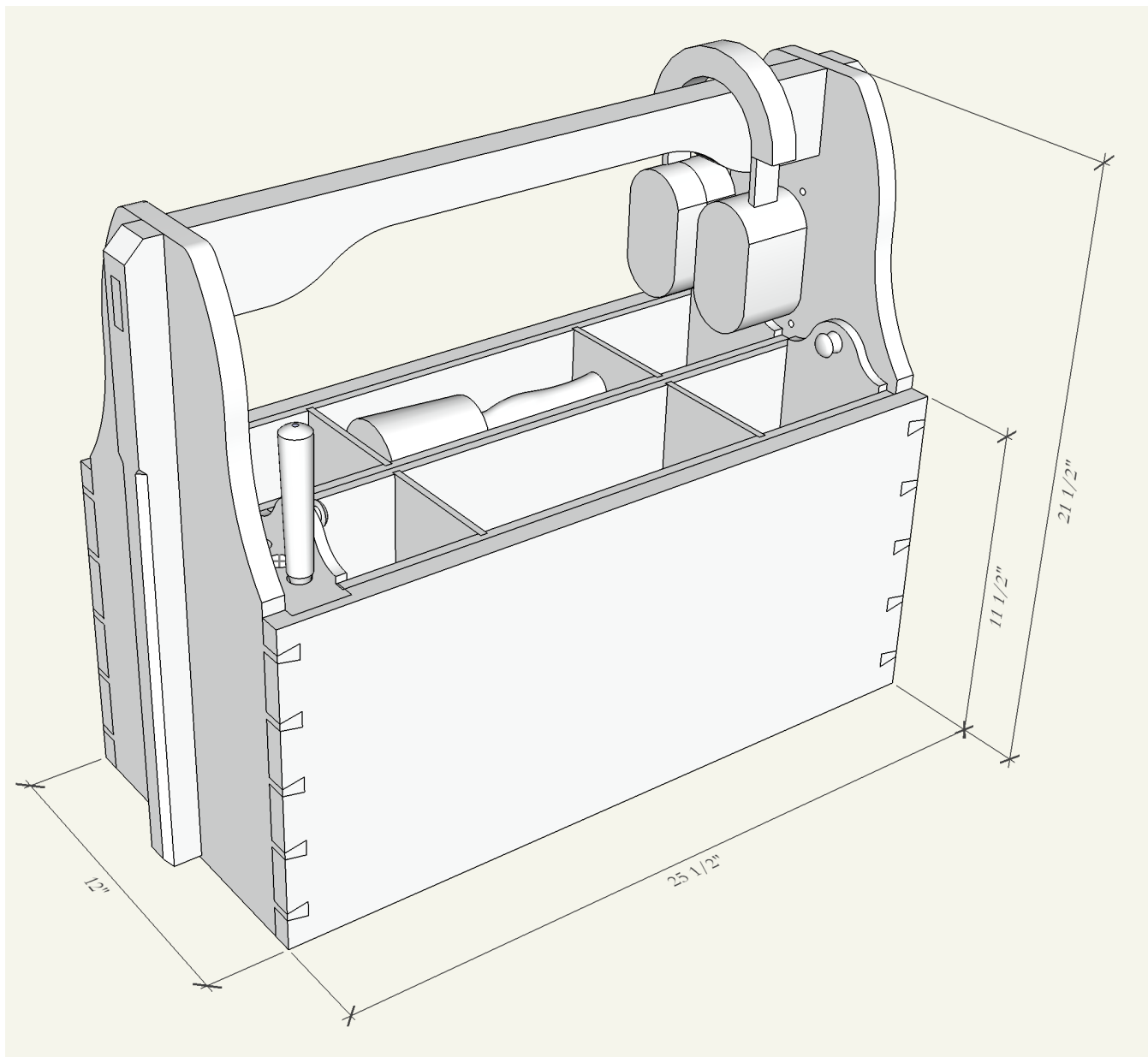

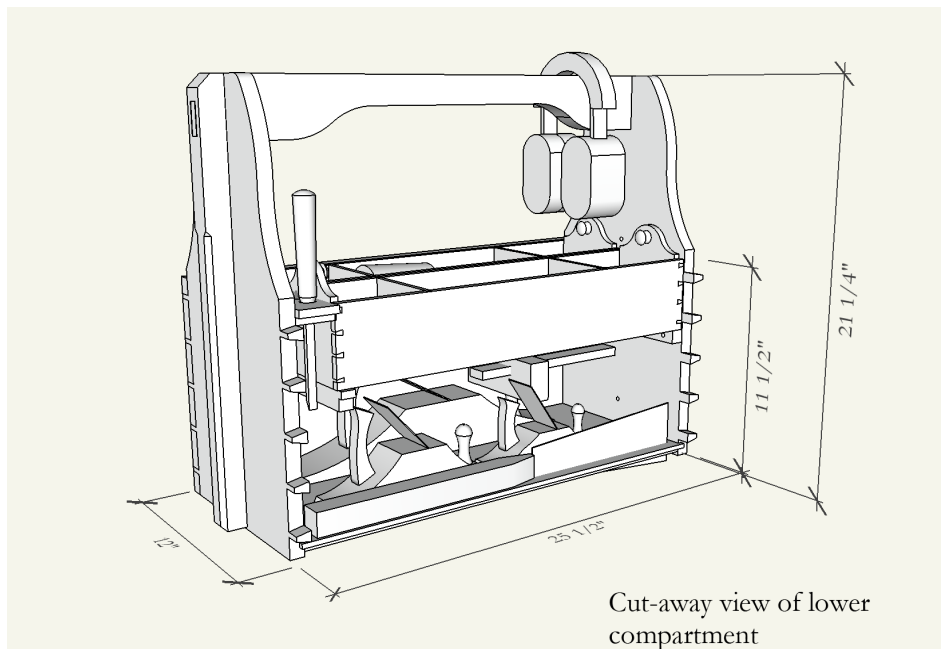
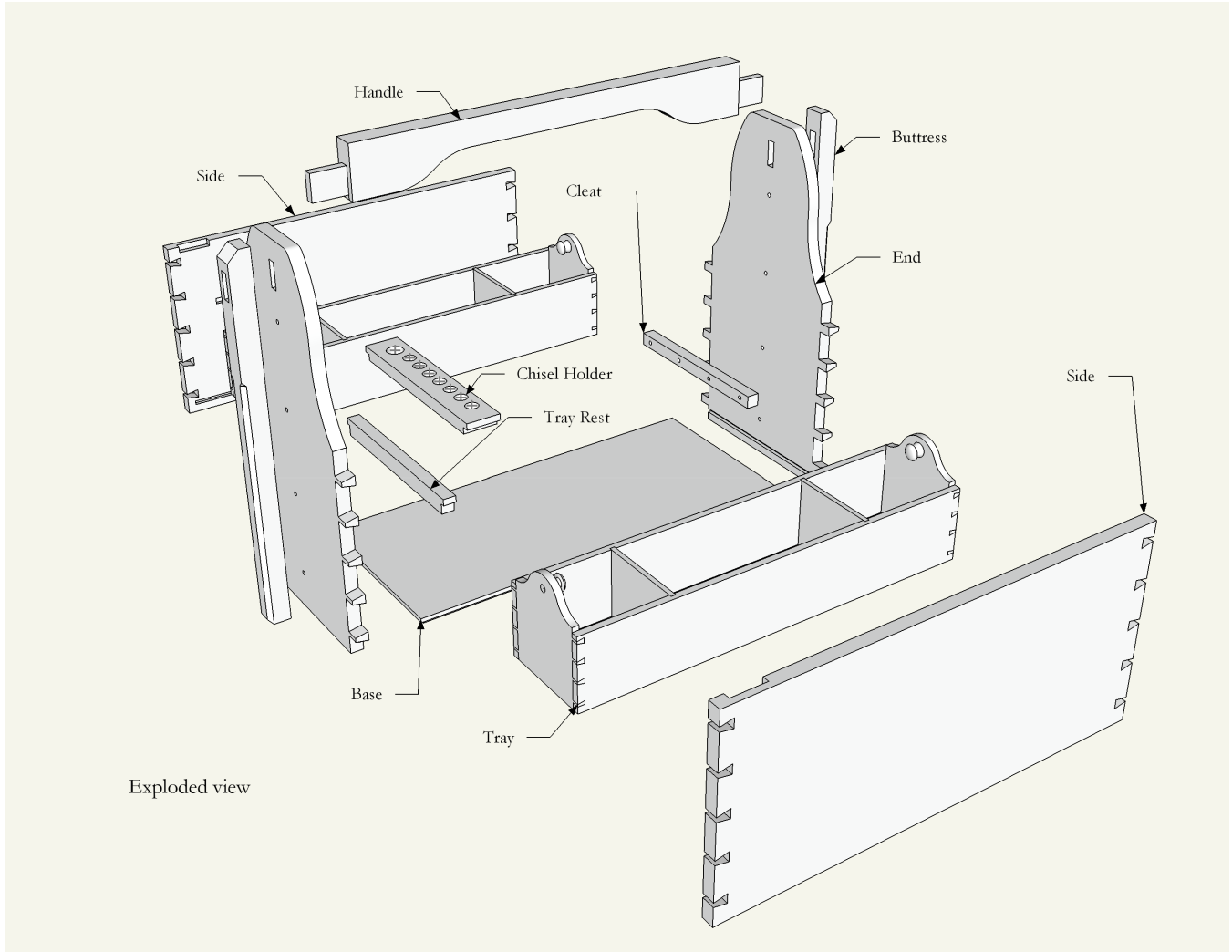

CUTTING AND ASSEMBLY NOTES

START WITH THE SIDES

If you have enough matching lumber, mark out the ends and sides, and label them so that the grain is continuous around the box.

Mark out the dovetails and then cut them with a handsaw.

Note the stopped grooves for the base, which can be cut with a router. Square off the ends of these grooves with a chisel.

Use chisels to cut the recesses for the chisel holder and tray support.

ADDITIONAL TIPS

1. Use a marking gauge to layout the base line of the dovetails on the side pieces. You could also use a straight edge and a sharp knife to scribe the baseline and then layout the dovetails. A Sliding T Bevel Square can be helpful for this. After cutting the sides of the tails clear out the waste with a coping saw and chisels.
2. Cut the recesses for the chisel support using a combination of a hand saw and chisels. Cut angles with the saw and clear out the waste with chisels.
3. Cut the mortise for the tray support using a drill bit and chisels.

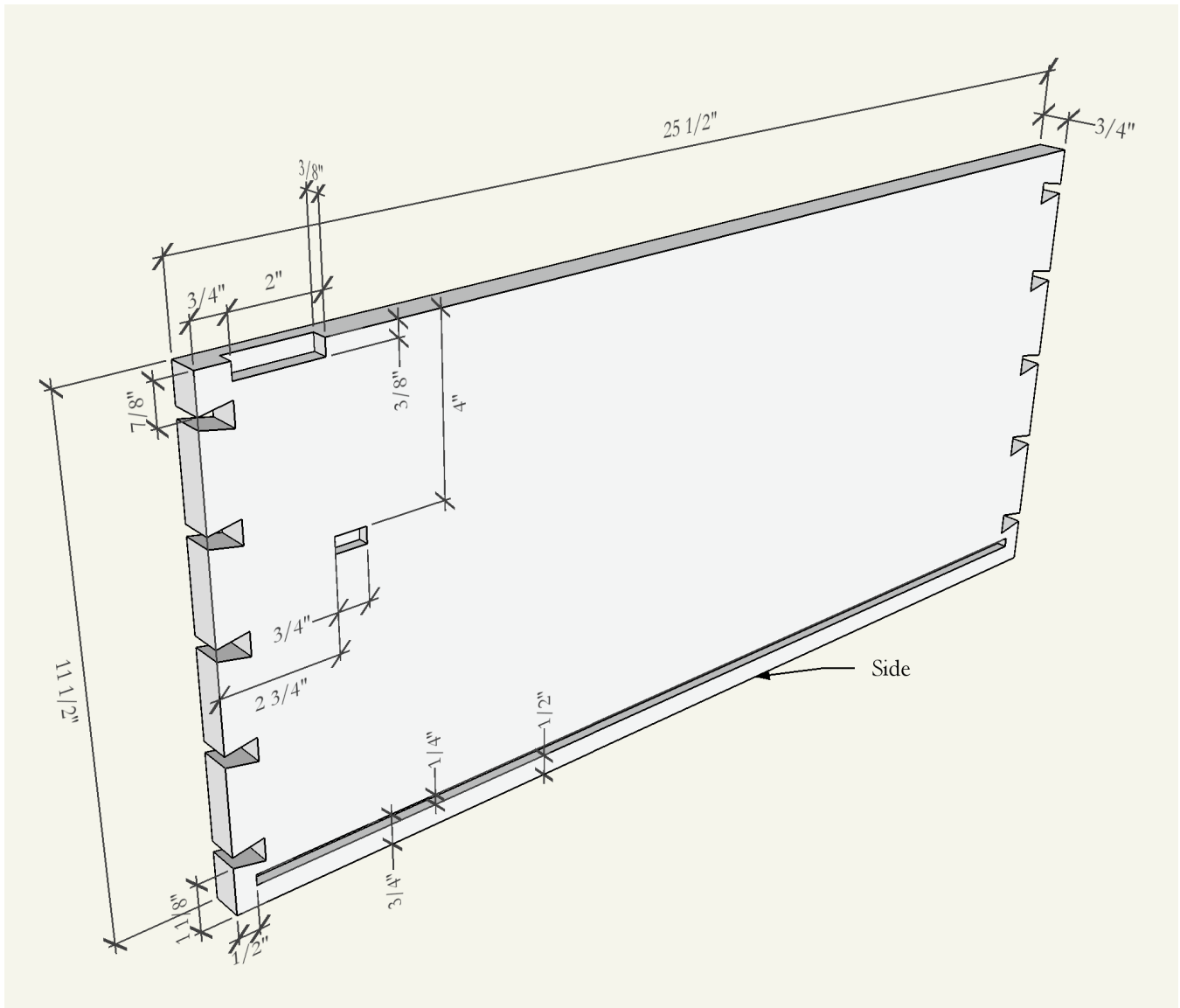

CUTTING AND ASSEMBLY NOTES

FABRICATE THE ENDS, BASE AND PART OF THE INSIDE

Use the side pieces as guides to lay out the dovetail pins on the ends.

Next, cut the grooves for the base and mortise for the handle. The mortise can be roughed out on the drill press, then squared with a chisel.

Drill the shank holes for the screws used to fasten the end to the buttresses.

Now, cut out the base, which is made of plywood to avoid expansion/contraction issues. You can use either 1/2-in. or 3/8 in. material.

Cut out the tray rest and cleat.

Although you have a lot of parts ready at this point, do not be tempted to glue anything together until other critical parts - base, handle, and tray support - are fabricated.

ADDITIONAL TIPS

1. The side pieces need to have the grain running horizontally so that the Dovetail Pins are not weakened if the grain runs vertically. You'll have to glue up at least two pieces to achieve the finished height. Hold the side pieces with the tails on top of the edge of the pieces that will have the Dovetail Pins. Use a sharp knife to scribe the tails onto the end pieces. Cut the pins and clear out the waste with a coping saw and chisels. Make sure that you cut on the waste side of the scribe lines.

Woodworker's Tip: You can hold the end pieces in a woodworkers vise so that you can scribe the tails onto the pin board. Cut the scroll shape on the ends with a Band Saw or Jig Saw.

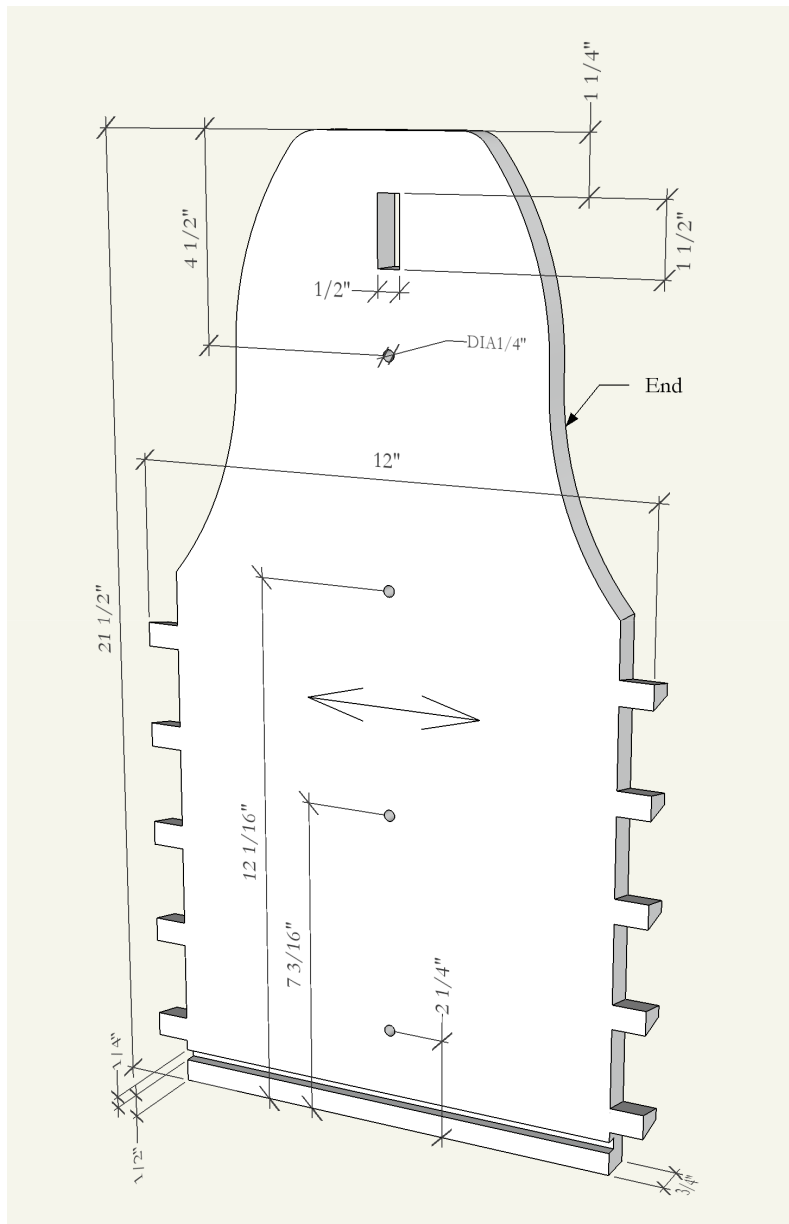

CUTTING AND ASSEMBLY NOTES

1. Using a table saw cut the tongues on the base to fit in the grooves on the sides and ends. Make sure that the tongues do not bottom out in the grooves so that the bottom doesn't keep the case from going together completely.
2. Use the table saw again to cut the tenons on the tray rest.

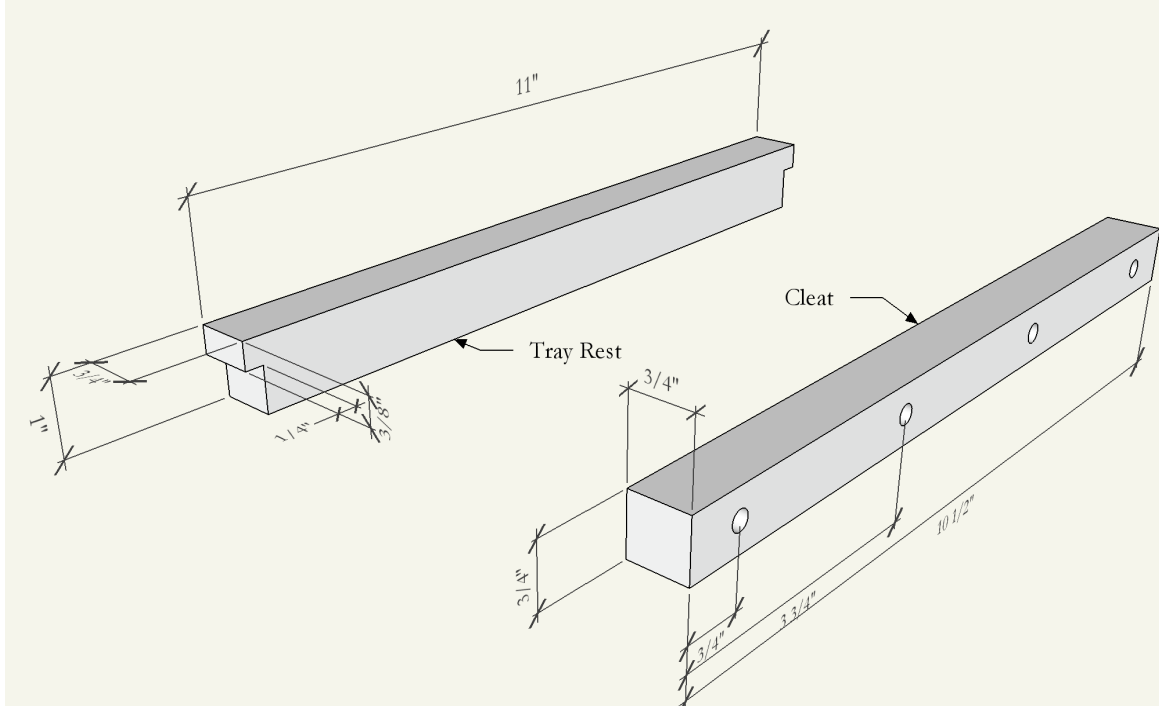
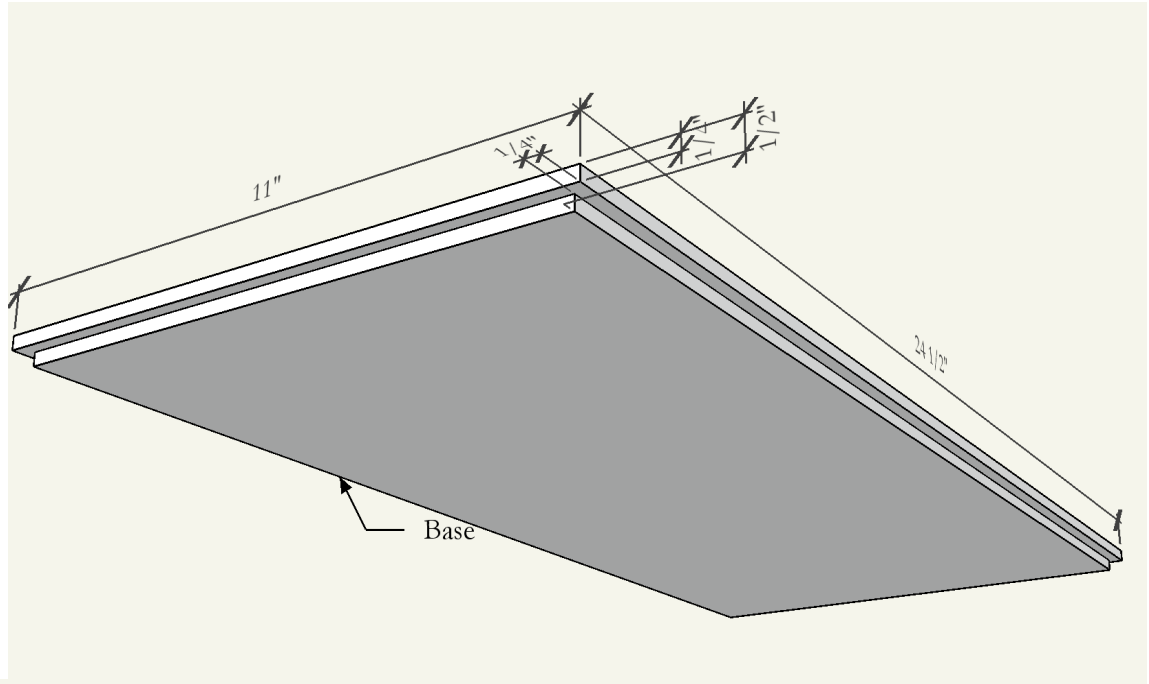

CUTTING AND ASSEMBLY NOTES

ASSEMBLE SIDES, ENDS, HANDLE, BASE, AND TRAY SUPPORT

Dry fit all parts and prepare for gluing the assembly. Consider using a slower drying glue, as it may take more time to manage the many parts.

Begin the glue up on one set of dovetail joints connecting a side and end. Add the other side while connecting in the tray support. Connect the other end while fitting in the handle.

Screw the cleat to the end.

ADDITIONAL TIPS

1. The table saw with a tenoning jig is a good way to cut the tenons on the handle.
2. It's a good idea to sand the interior of the case before glue up.
3. It can be helpful to use painter's tape where you will be gluing the pieces together, especially inside corners.

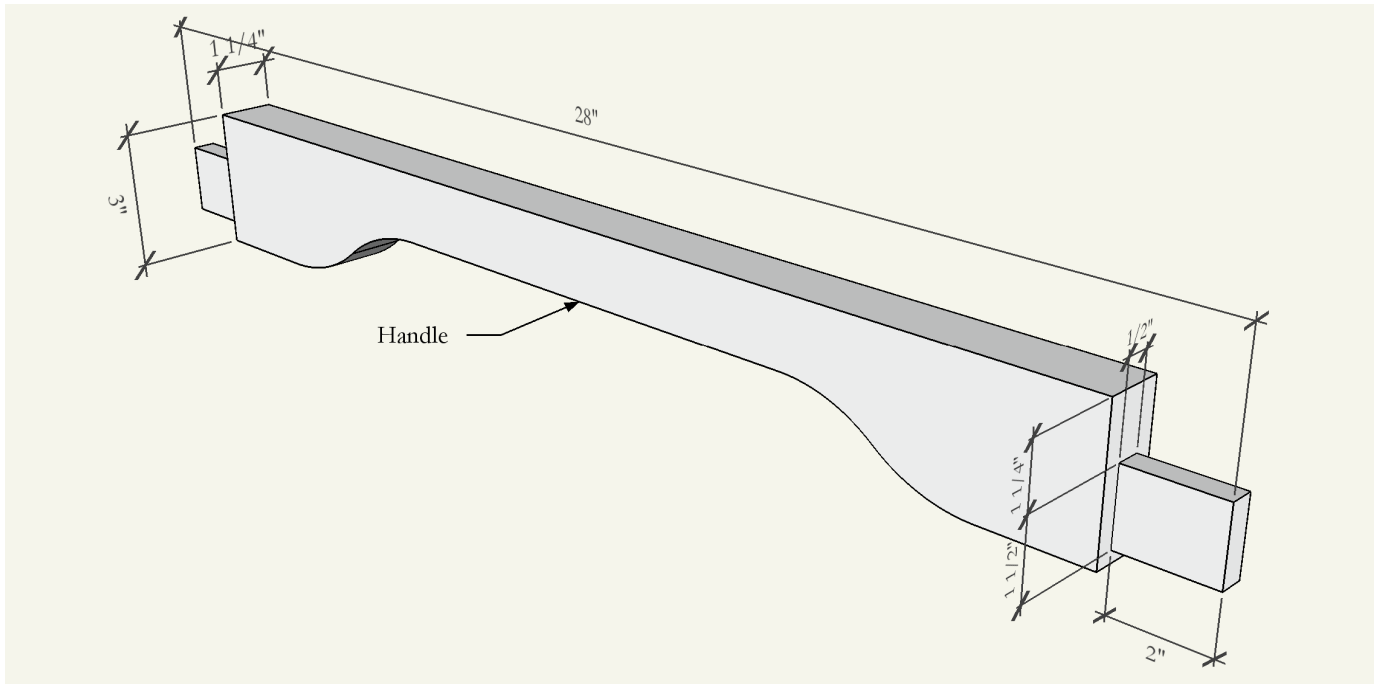

CUTTING AND ASSEMBLY NOTES

MILL THE BUTTRESSES

To avoid cross-grain expansion contraction issues, this piece should be glued only along the upper 6 in. of the buttress. Four screws fasten the buttress to the ends. The shank holes should be oversized to about 1/4 in. dia., to allow for movement.

The bottom edge of the buttress should be 1/8 in. short of the bottom edge of the end. This gap prevents the buttress bottom from contacting surfaces when putting the tool case down.

Note the chamfers on the buttress top, sides and bottom end.

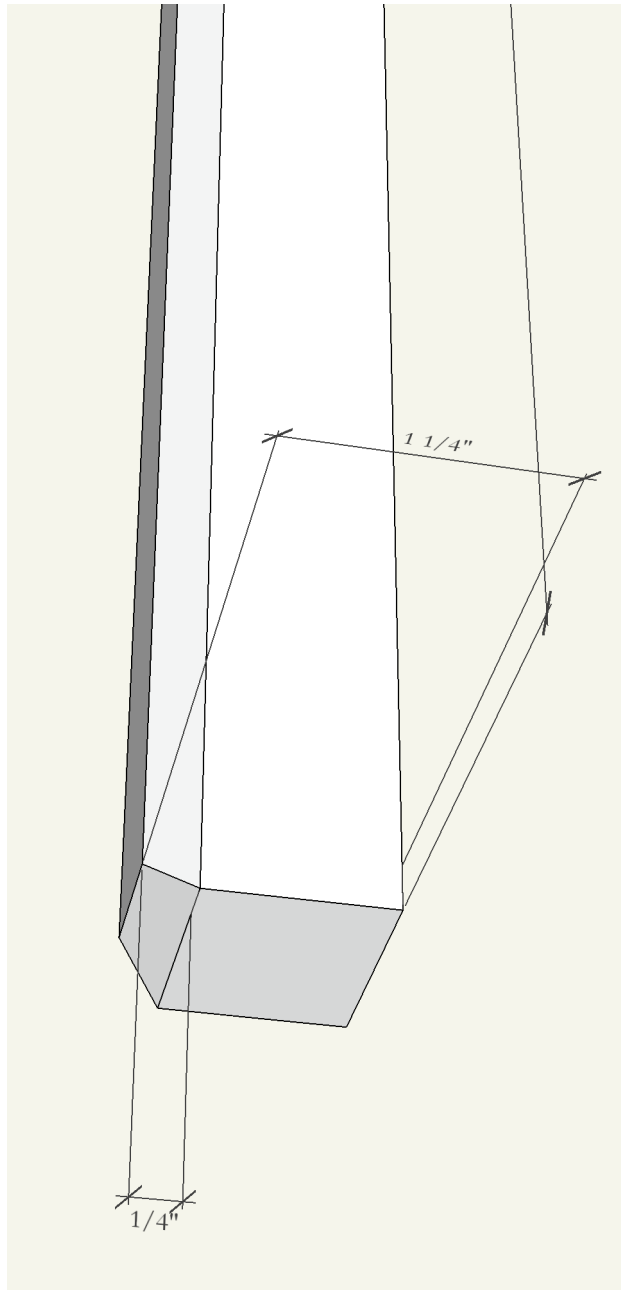
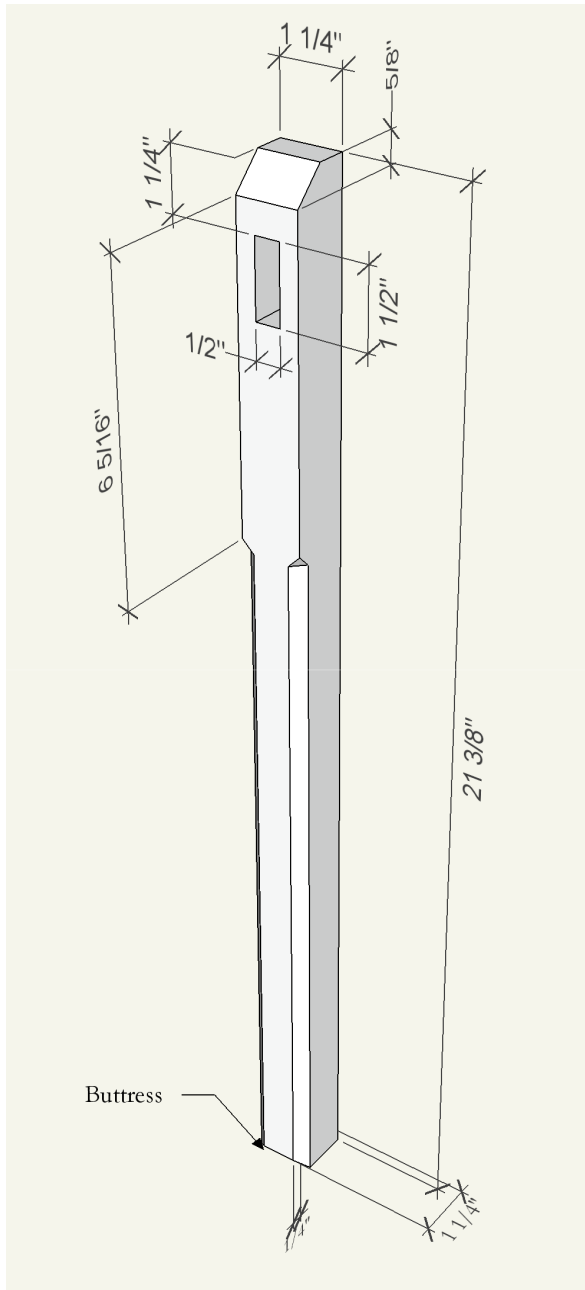

CUTTING AND ASSEMBLY NOTES

MAKE UP THE CHISEL HOLDER

Use your own tools as a guide for the diameter of the chisel holder holes.

Glue the chisel holder in place; it attaches to the side cutouts and the end piece.

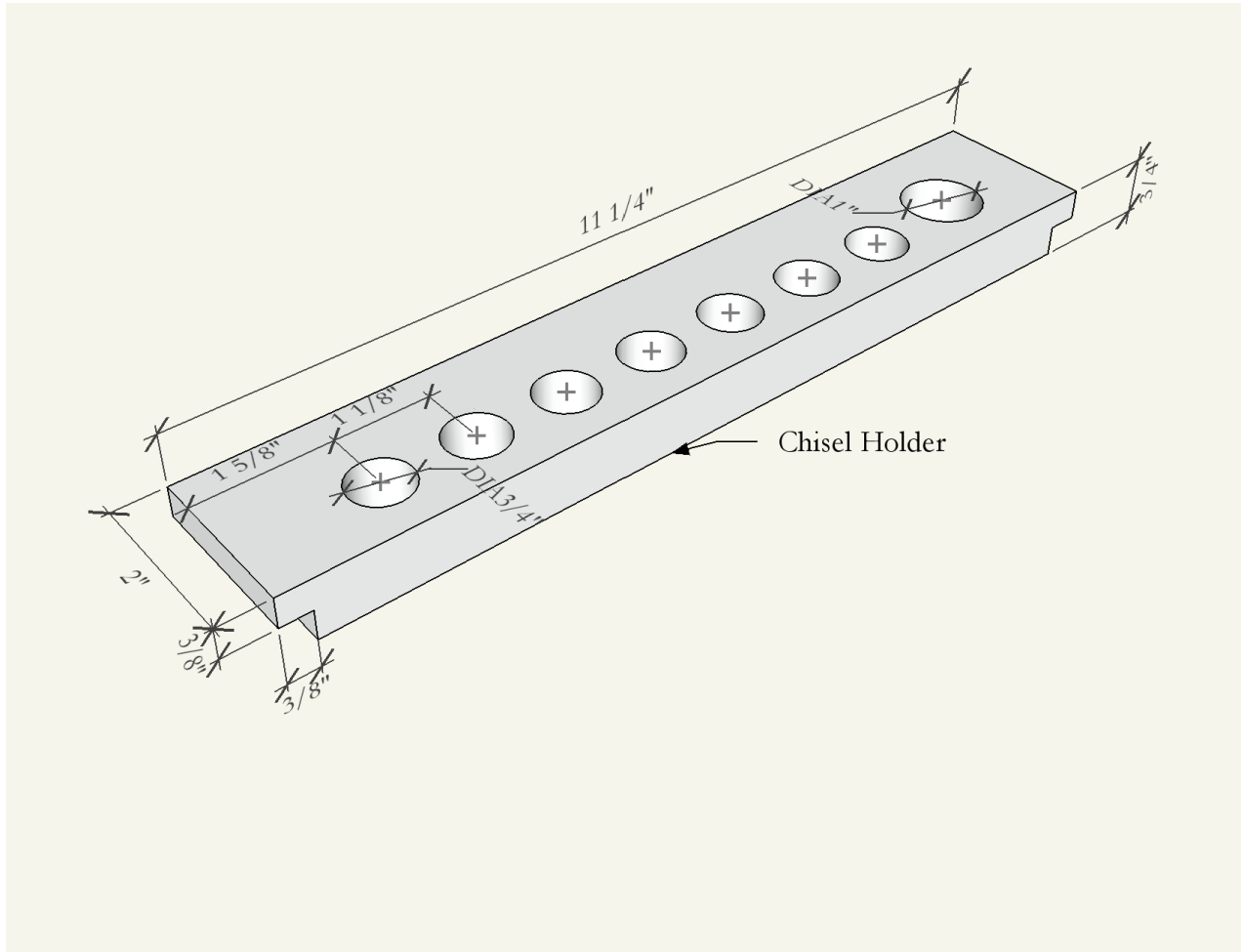

CUTTING AND ASSEMBLY NOTES

THE TRAYS ARE NEXT

There are two trays each with dividers to suit. As an alternative, one tray may be full-length without dividers.

The trays are dovetailed. Grain direction of the tray ends is horizontal to match grain of the sides.

Tray construction is very much like that for the main box including a captured base in side and end grooves. The grooves in the sides are stopped short and squared off by hand.

Check the actual length dimension for the dividers after assembly of the tray sides, ends, and bottom.

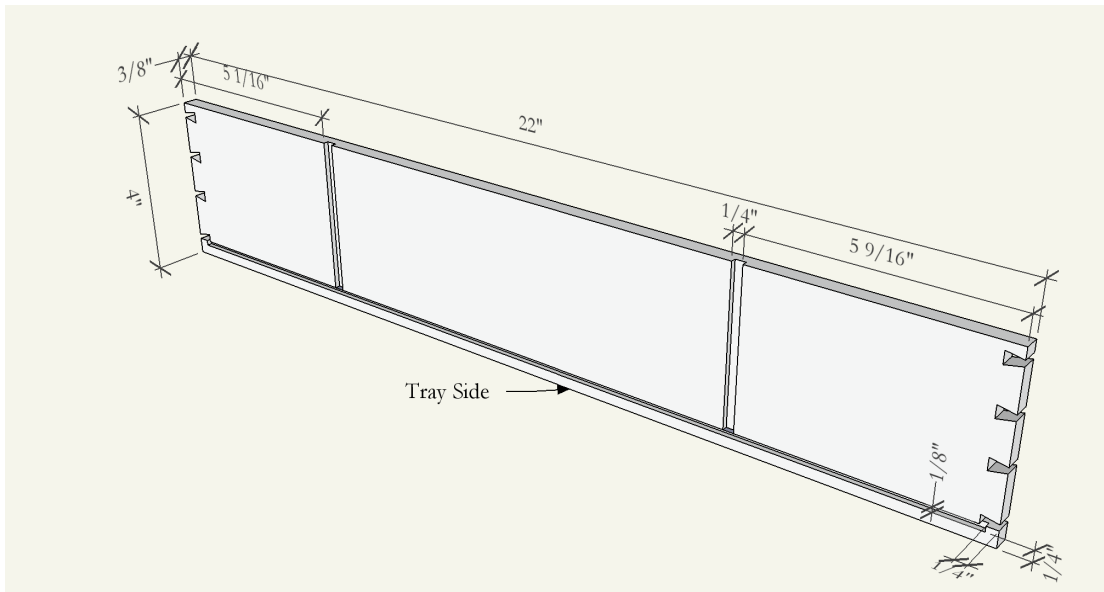
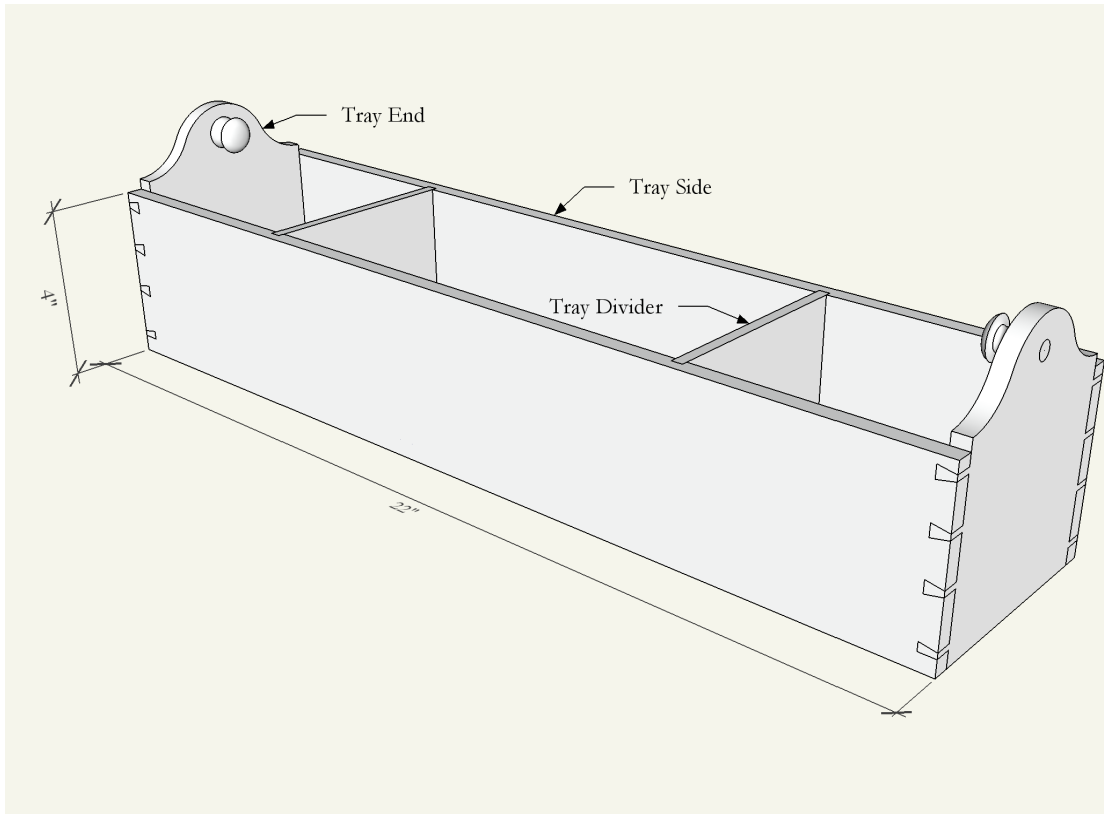

CUTTING AND ASSEMBLY NOTES

OTHER TRAY PARTS

Before glue up of sides and ends, have the bottom piece ready as it is captured in the side and end grooves.

Check actual length dimension for the dividers after assembly of the tray sides, ends, and bottom.

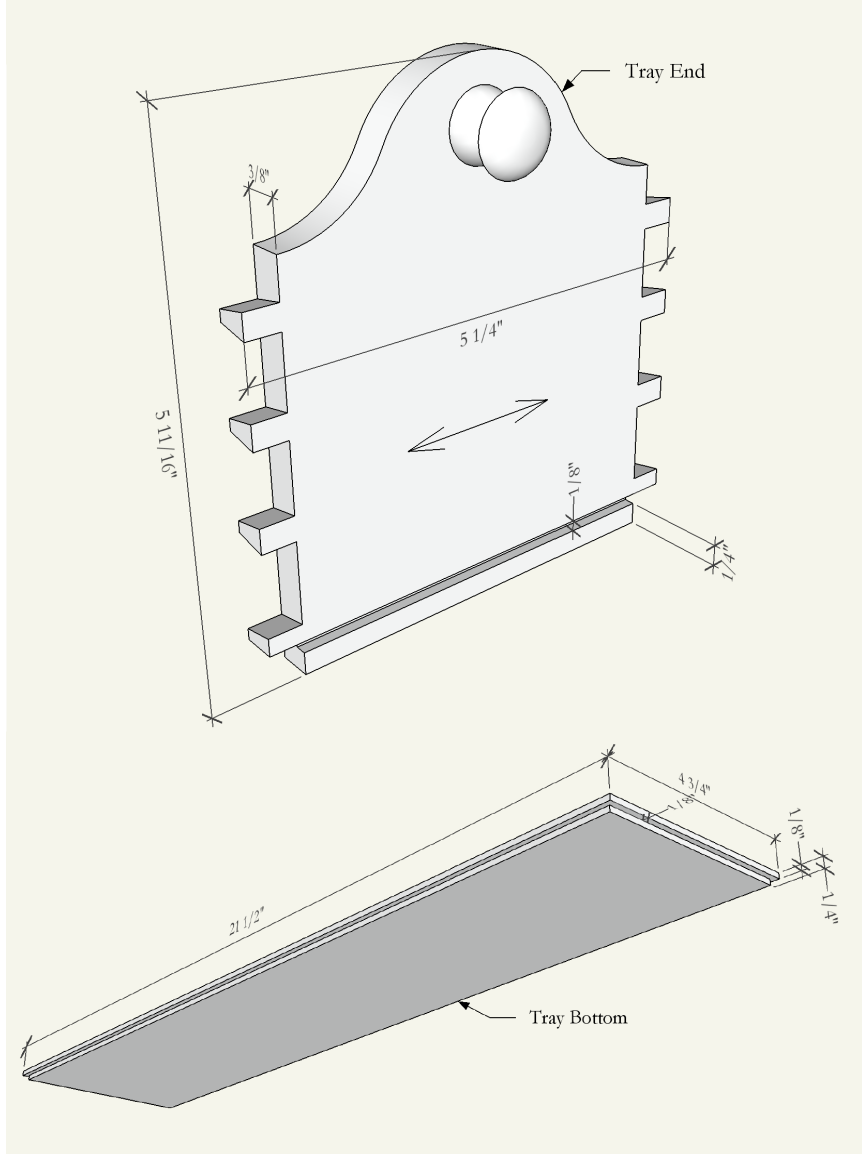
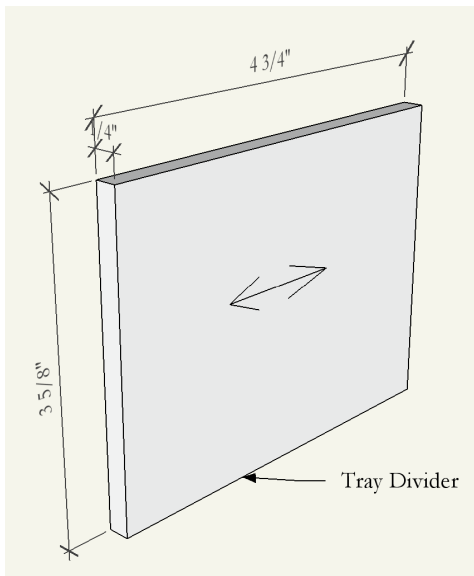
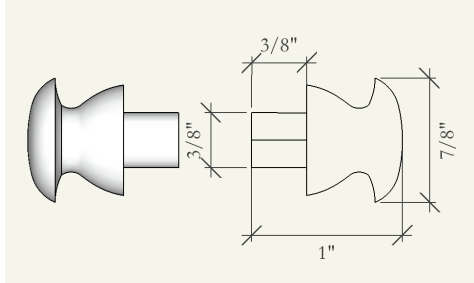

STAINING AND FINISHING

Woodworker's Tip: *Though you may be tempted to cut short your sanding, preparation, and application time, don't do it. These tasks are very important steps in obtaining a high-quality finish. Remember, it is the finish, just as much as the fit and smoothness of the parts, that will have an impact on how people judge your craftsmanship. To ensure excellent results, follow the steps listed in this section and the instructions the wood finishing manufacturer puts on its products.*

FINISHING TIPS

- Test the stain and clear protective finish you are planning to use on scraps of wood. On the back of the scrap, mark the stain and finish combination and the type of wood. Allow all samples to dry thoroughly before making your final finish selection. Save your samples for quick reference on future projects.
- All stains and clear protective finishes must be allowed to dry thoroughly between coats. Remember that drying times can vary due to temperature, humidity, and other climatic conditions.
- If you have some leftover stain or finish, wipe the can rim so that stain or finish in the rim won't dry out and prevent the lid from forming a tight seal.

BEFORE YOU STAIN

Carefully sand the pieces following the grain. Start with 100-grit sandpaper, proceed to 150-grit and finish with 220-grit. Remove all the sanding dust. Then proceed with the stain and finish of your choice.

RECOMMENDED STAIN AND CLEAR FINISH

Prep: Minwax® Pre-Stain Wood Conditioner (oil-based)

Stains: Minwax® Wood Finish™, Early American

Finish: Minwax® Helmsman® Spar Urethane, Semi-Gloss

1. Before applying Minwax® Wood Finish™, apply oil-based Minwax® Pre-Stain Wood Conditioner, following the directions on the can. Applying a pre-stain wood conditioner will help to ensure even absorption of stain and prevent blotchiness.
2. Before use and occasionally during application, stir Minwax® Wood Finish™.
3. Apply the Minwax® Wood Finish™ color you have chosen using a brush or a clean, lint-free cloth, following the directions on the can. The natural bristle brush will help you get the stain into the inside corners. Allow the Minwax® Wood Finish™ stain to sit for 5 to 15 minutes, and then wipe off any excess. To achieve a deeper color, you may apply a second coat after 4 to 6 hours, repeating the application directions for the first coat. Allow the stain to dry for 8 hours before applying the clear protective finish.

Woodworker's Tip: *When wiping off stain, make certain that your last wipe with the cloth goes with the grain of the wood.*

4. Once the stain has dried the recommended time, apply two coats of Minwax® Helmsman® Spar Urethane following the directions on the can. Before applying, and in between coats, lightly sand the surface and remove all dust. Stir Helmsman® well before and during use. In between coats, lightly sand the surface and remove all dust. Using a good quality, natural-bristle brush, apply thin coats. Allow the finish to cure for several days before installing the nesting trays.

PRODUCT SAFETY

For your safety and the safety of those you work with, always read the manufacturer's safety warnings, and follow them to the letter.

WARNING! Removal of old paint by sanding, scraping or other means may generate dust or fumes that contain lead. Exposure to lead dust or fumes may cause brain damage or other adverse health effects, especially in children or pregnant women. Controlling exposure to lead or other hazardous substances requires the use of proper protective equipment such as a properly fitted respirator (NIOSH approved) and proper containment and cleanup. For more information, call the National Lead Information Center at 1-800-424-LEAD (in US) or contact your local health authority.

DANGER: Rags, steel wool, other waste soaked with this product, and sanding residue may spontaneously catch fire if improperly discarded. Immediately place rags, steel wool, other waste soaked with this product, and sanding residue in a sealed, water-filled, metal container. Dispose of in accordance with local fire regulations.

CAUTION: CONTAINS ALIPHATIC HYDROCARBONS.

Contents are COMBUSTIBLE. Keep away from heat and open flame.

VAPOR HARMFUL. Use only with adequate ventilation. To avoid overexposure, open windows and doors or use other means to ensure fresh air entry during application and drying. If you experience eye watering, headaches, or dizziness, increase fresh air, or wear respiratory protection (NIOSH approved) or leave the area. Avoid contact with eyes and skin. Wash hands after using. Keep container closed when not in use. Do not transfer contents to other containers for storage.

FIRST AID: In case of eye contact, flush thoroughly with large amounts of water for 15 minutes and get medical attention. For skin contact, wash thoroughly with soap and water. In case of respiratory difficulty, provide fresh air and call physician. If swallowed, call Poison Control Center, hospital emergency room, or physician immediately.

DELAYED EFFECTS FROM LONG TERM OVEREXPOSURE.

Contains solvents which can cause permanent brain and nervous system damage. Intentional misuse by deliberately concentrating and inhaling the contents can be harmful or fatal.

WARNING: This product contains chemicals known to the State of California to cause cancer and birth defects or other reproductive harm.

DO NOT TAKE INTERNALLY. KEEP OUT OF THE REACH OF CHILDREN.

CONFORMS TO ASTM D-4236. Contact a physician for more health information.