

WOODWORKS: INTERMEDIATE PROJECT 2009-2010
WIFFLE BALL

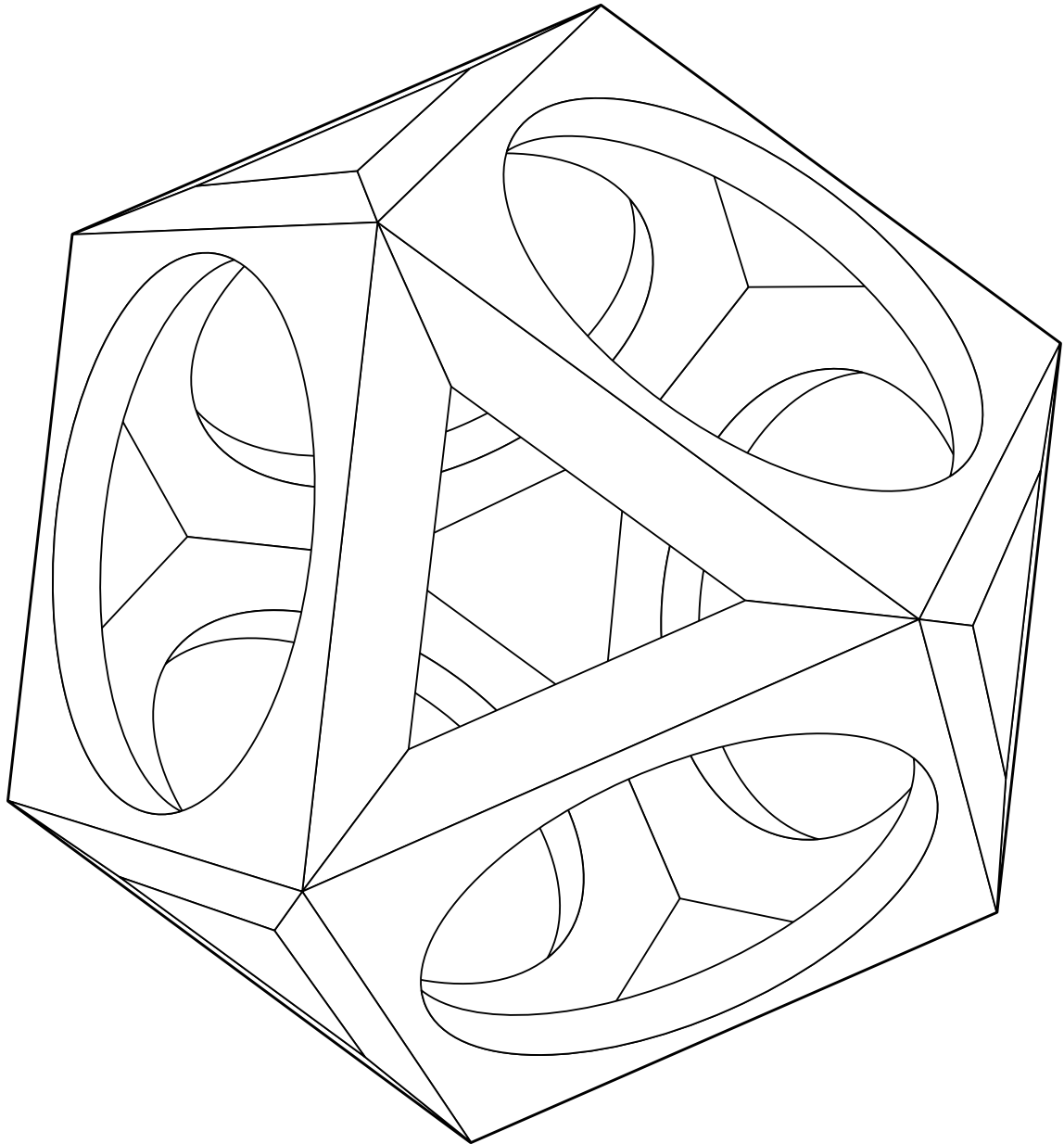

Here's a project that looks like a complicated puzzle, but it's really all about basic precision. It's made from just six identical little hardwood squares, all of them drilled and edge-mitered to fit together perfectly and then cut at the corners to make the final shape. Can you figure it out? We'll help you. Making this piece will give intermediate woodworkers the opportunity to hone their skills at cutting perfect squares and miters as well as boring large holes. And when it's all assembled, you'll learn more about applying and using stains and finishes to protect the wood and keep it looking beautiful.

TOOLS REQUIRED

Hand Tools

- Combination or try square
- Toggle clamps

Power Tools

- Table saw
- Drill press fitted with a 2-1/8" Forstner bit
- Random-orbit sander

Miscellaneous

- Pencil
- Tape measure
- Safety glasses
- Carpenter's glue
- 120-, 150- and 220-grit sandpaper
- Clean, lint-free cloths
- Respirator
- Gloves for finishing
- Mineral spirits (for oil-based stains and finishes)
- Water-filled metal container with tight-fitting lid (for oil-based stains and finishes)
- Minwax® Wood Finish™ Stain Brush or other good quality, natural-bristle brush (for oil-based stains and finishes)
- Minwax® Polycrylic Brush or other good quality synthetic-bristle brush (for water-based stain and finishes)

SHOPPING LIST

Wood Recommendation: White Oak

Alternate Wood: Walnut

Qty.	Th. x W x L
2	1/4" x 3-1/2" x 24"

CUTTING LIST

Size & Quantity

1/4" x 3-1/2" x 3-1/2" squares, 12 total; six for testing, six for the piece

WOOD FINISHING PRODUCTS

Recommended Finish

Prep: Minwax® Pre-Stain Wood Conditioner
 Stain: Minwax® Gel Stain Brazilian Rosewood
 Finish: Minwax® Fast-Drying Polyurethane (Semi-Gloss)

Alternate Finish

Prep: Minwax® Water-Based Pre-Stain Wood Conditioner
 Stain: Minwax® Water-Based Wood Stain Colonial Pine
 Finish: Minwax® Polycrylic® Protective Finish (Gloss)

BEFORE YOU BEGIN

Good craftsmanship begins and ends with good work habits, so make the following steps part of your routine workshop practice. If you have any doubts or questions about how to proceed with a project, always discuss them with your shop instructor.

- Carefully and fully review plans and instructions before putting a tool to the project lumber.
- Work sensibly and safely. Wear safety goggles when doing work that creates flying chips and sawdust; wear the appropriate respirator whenever making sawdust or working with thinners or other solvents.
- At the end of every work session, clean up your shop area and put away all portable tools.

CUTTING AND ASSEMBLY PROCEDURE

1. Precise cuts, safely done, are essential to making the wiffle ball (see Fig. 1). To begin, build a small crosscut sled with a fence wide enough to support a toggle clamp (see Fig. 2).
2. Fasten two pieces of 1/4" tempered hardboard to the sled's bottom, centered over its slot. Butt the pieces together, then saw through the joint while raising the table saw blade.
3. Cut 12 3-1/2" squares from the two 1/4" x 3-1/2" x 24" blanks. Six are test pieces; the other six will make one wiffle ball. Put a roundhead screw in the holddown block to use as a finger-hold (see Fig. 4) and help you position the block. Add a plastic shield to deflect sawdust (see Fig. 2).
4. Remove the sled and tilt the saw blade to 45°. For the best results, use a 60-tooth crosscut blade for every cut on this project.
5. Remove both pieces of hardboard from the sled. Turn around the left piece and refasten it to the sled. Cut an angled slot all the way across it. Toss the waste piece.
6. On many contractor's saws, the blade moves out of square when it's tilted. Hold a wiffle blank against the blade and fence. Tape a shim to the fence if there's a gap at one corner (see Fig. 3).
7. Miter all four sides of a test piece (see Fig. 4). Start with an end-grain edge, then turn it counterclockwise as you go. Position the stop block so that you just cut the blank's edges but don't shorten the blank. Reposition the toggle clamp and plastic shield for these cuts.
8. After the miter cuts, check to assure that the piece is perfectly square. Adjust the shim if it isn't, then cut four more test pieces.
9. Check the angle of the miter cuts by holding the four test pieces together. You may have to slightly adjust the blade's tilt to make these joints dead tight. Once you're set, miter all six "real" pieces.
10. Drill a 2-1/8"-dia. hole in the center of each piece using a Forstner bit. Make a little holding jig to lock in the piece on three sides and ensure that it doesn't shift during drilling. Fasten a couple of toggle clamps to the jig sides to keep your fingers out of the way.

11. Tape four pieces together. Butt four of the squares against a straightedge and tape them together. Add the remaining two squares to make a T as shown in Fig. 5 and tape them to the group of four.

12. Turn over the assembly and spread glue on all the joints.

13. Fold the pieces into a cube. Put lots of short pieces of tape on the cube to hold the joints tight. Let the glue dry overnight, then remove the tape.

14. Add the right-hand hardboard piece and two support blocks to the sled (see Fig. 6). Support piece A is 1-1/8" thick x 2-1/8" wide; support piece B is 1-3/4" thick x 2-3/8" wide. Cut 45° miters on both pieces (see Fig. 7).

15. Mark a centerline on the cube, then adjust the support boards side-to-side on the sled fence until the centerline falls exactly on the left side of the sled's saw kerf. The cube should also fit tight against both support boards.

16. Cut all eight corners to transform the cube into a wiffle ball. Set the blade 3/8" above the sled, then rotate the cube three times, making three cuts, to remove each corner.

STAINING AND FINISHING

Woodworker's Tip: *Though you may be tempted to cut short your sanding, preparation and application time, don't do it. These tasks are very important steps in obtaining a high-quality finish. Remember, it is the finish, just as much as the fit and smoothness of the parts that will have great bearing on how people judge your craftsmanship. To ensure an excellent result, follow the steps listed in this section and also the instructions the finish manufacturer puts on its products.*

FINISHING TIPS

- Test the stains and finishes you are planning to use on scraps of wood. On the back of the scrap, mark the stain/finish combination and the type of wood. Allow all samples to dry thoroughly before making your final finish selection. Save your samples for quick reference on future projects.
- All stains and finishes must be allowed to dry thoroughly between coats. Remember that drying times can vary due to humidity and other climatic conditions.
- If you have some leftover stain or finish, wipe the can rim so that stain or finish in the rim won't dry out and prevent the lid from forming a tight seal.
- Brushes used for oil-based finishes must be cleaned with mineral spirits.

17. Sand the wiffle ball surfaces and all exposed edges, starting with 120-grit and finishing with 220-grit sandpaper. Dust off the piece and wipe it carefully with a clean, lint-free cloth lightly dampened with mineral spirits.

Recommended Finish

18. Before applying Minwax® Gel Stain to a hardwood or softwood, apply Minwax® Pre-Stain Wood Conditioner following the directions on the can.

19. Do the staining in two steps, starting on the interior surfaces and then do to the exterior surfaces. Apply Minwax® Gel Stain using a clean, lint-free cloth or natural-bristle brush. Follow the directions on the can. Allow the Gel Stain to set for about 3 minutes, then wipe off any excess with a clean, lint-free cloth. To achieve a deeper color, you may apply a second coat after 8 to 10 hours, repeating the application directions for the first coat. Allow the stain to dry for 24 hours before applying the finish.

Woodworker's Tip: *When wiping off stain, make certain that your last wipe with the cloth goes with the grain of the wood. This way, any stain you might miss during wipe-off will be visually minimized by the wood grain.*

20. Apply Minwax® Fast-Drying Polyurethane following the directions on the can. Use a good quality, natural-bristle brush. Allow the first coat to dry overnight.

21. The next day, sand all surfaces lightly with 220-grit or finer sandpaper using with-the-grain strokes. Dust off and wipe all surfaces with a cloth lightly dampened with mineral spirits. Apply a second coat of polyurethane and set the piece aside to cure overnight.

22. The following day, sand all surfaces lightly with 220-grit paper. Dust off and wipe the piece with a cloth lightly dampened with mineral spirits and apply the third and final coat of polyurethane.

Alternate Finish

23. Before applying Minwax® Water-Based Wood Stain to a hardwood or softwood, apply Minwax® Pre-Stain Water-Based Wood Conditioner following the directions on the can. Applying the conditioner will help to ensure even absorption of stain and prevent blotchiness that can occur with some woods. After 1 to 5 minutes, wipe off all excess conditioner using a clean, soft cloth. Wait 15 to 30 minutes, then use 220-grit or finer sandpaper to sand off any "whiskers" raised by the conditioner. Proceed to the staining within 2 hours.

24. Do the staining in two steps, starting on the interior surfaces and then do to the exterior surfaces. Apply the Minwax® Water-Based Wood Stain you've chosen to the wood using either a nylon/polyester brush or a cloth. Allow stain to penetrate no longer than 3 minutes. While stain is still wet, wipe off all excess with a clean cloth that's been lightly dampened with stain. Allow the piece to dry for 2 hours before applying a second coat, if desired. Allow the piece to dry overnight before applying the protective clear finish.

Woodworker's Tip: *Minwax® Water-Based Wood Stain is available in 6 wood-tones, a White Wash Pickling Stain, 60 custom-mixed colors, and 8 bold Accents™ colors. This means that you are not limited to just traditional wood colors (pine, oak, walnut, etc.). Instead, you can pick and apply a color to complement the décor of the room in which the bench will be placed. For this reason, make sure you look over all of the Minwax® color charts or go to minwax.com before making your final selection.*

25. After allowing the piece to dry overnight, apply Minwax® Polycrylic® Protective Finish following the directions on the can. Stir the can contents thoroughly before starting and periodically repeat the stirring during your work session.

26. Working a small area at a time to maintain a wet edge, apply the first coat. Work quickly and make the final strokes in each newly finished section using with-the-grain brushstrokes.

27. Allow the finish to dry a minimum of 2 hours. Then sand lightly with 220-grit or finer sandpaper wrapped around a soft backup block. Thoroughly dust off and wipe all surfaces with a cloth lightly dampened with water.

28. Repeat steps **25** and **26** to apply the second and final coat.

PRODUCT SAFETY

For your safety and the safety of those you work with, always read the safety warnings, which manufacturers print on their labels, and follow them to the letter. Typical safety advice and instructions will contain information such as the following:

WARNING! Removal of old paint by sanding, scraping or other means may generate dust or fumes that contain lead. Exposure to lead dust or fumes may cause brain damage or other adverse health effects, especially in children or pregnant women. Controlling exposure to lead or other hazardous substances requires the use of proper protective equipment, such as properly fitted respirator (NIOSH approved) and proper containment and cleanup. For more information, call the National Lead Information Center at 1-800-424-LEAD (in U.S.) or contact your local health authority.

When using oil-based wood finishing products:

CAUTIONS: CONTAINS ALIPHATIC HYDROCARBONS.

Contents are COMBUSTIBLE. Keep away from heat and open flame. **VAPOR HARMFUL.** Use Only With Adequate Ventilation. To avoid overexposure, open windows and doors or use other means to ensure fresh air entry during application and drying. If you experience eye watering, headaches, or dizziness, increase fresh air, or wear respiratory protection (NIOSH approved), or leave the area. Avoid contact with eyes and skin. Wash hands after using. Keep container closed when not in use. Do not transfer contents to other containers for storage.

FIRST AID: In case of eye contact, flush thoroughly with large amounts of water for 15 minutes and get medical attention. For skin contact, wash thoroughly with soap and water. In case of respiratory difficulty, provide fresh air and call physician. If swallowed, call Poison Control Center, hospital emergency room, or physician immediately.

NOTICE: Reports have associated repeated and prolonged occupational exposure to solvents with permanent brain and nervous system damage. Intentional misuse by deliberately concentrating and inhaling contents may be harmful or fatal.

WARNING: This product contains a chemical known to the State of California to cause cancer and birth defects or other reproductive harm. **DO NOT TAKE INTERNALLY. KEEP OUT OF REACH OF CHILDREN.**

When using water-based wood finishing products:

CAUTIONS: Use Only With Adequate Ventilation. To avoid overexposure, open windows and doors or use other means to ensure fresh air entry during application and drying. If you experience eye watering, headaches, or dizziness, increase fresh air, or wear respiratory protection (NIOSH approved), or leave the area. Avoid contact with eyes and skin. Wash hands after using. Keep container closed when not in use. Do not transfer contents to other containers for storage.

FIRST AID: In case of eye contact, flush thoroughly with large amounts of water. Get medical attention if irritation persists. If swallowed, get medical attention immediately.

WARNING: Contains Alkyl propanols, ethylene glycol, n-methyl pyrrolidone. **VAPOR HARMFUL.** Use only with adequate ventilation. To avoid overexposure, open windows and doors or use other means to ensure fresh air entry during application and drying. If you experience eye watering, headaches, or dizziness, increase fresh air, or wear respiratory protection (NIOSH approved), or leave the area. Avoid contact with eyes and skin. Wash hands after using. Keep container closed when not in use. Do not transfer contents to other containers for storage.

DO NOT TAKE INTERNALLY.

FIRST AID: In case of eye contact, flush thoroughly with large amounts of water for 15 minutes and get medical attention. For skin contact, wash thoroughly with soap and water. In case of respiratory difficulty, provide fresh air and call physician. If swallowed, call Poison Control Center, hospital emergency room, or physician immediately.

DELAYED EFFECTS FROM LONG-TERM OVEREXPOSURE.

Contains solvents which can cause permanent brain and nervous system damage. Intentional misuse by deliberately concentrating and inhaling contents may be harmful or fatal.

WARNING: This product contains a chemical known to the State of California to cause cancer and birth defects or other reproductive harm. **KEEP OUT OF REACH OF CHILDREN.**

SAFE DISPOSAL OF RAGS AND WASTE.

DANGER: Rags, steel wool, other waste soaked with this product, and sanding residue may spontaneously catch fire if improperly discarded. Immediately place rags, steel wool, other waste soaked with this product, and sanding residue in a sealed, water-filled metal container. Dispose of in accordance with local fire regulations.

This project originally appeared in *American Woodworker* magazine, #132, November 2007, page 58.

American.
Woodworker

FIG 1.

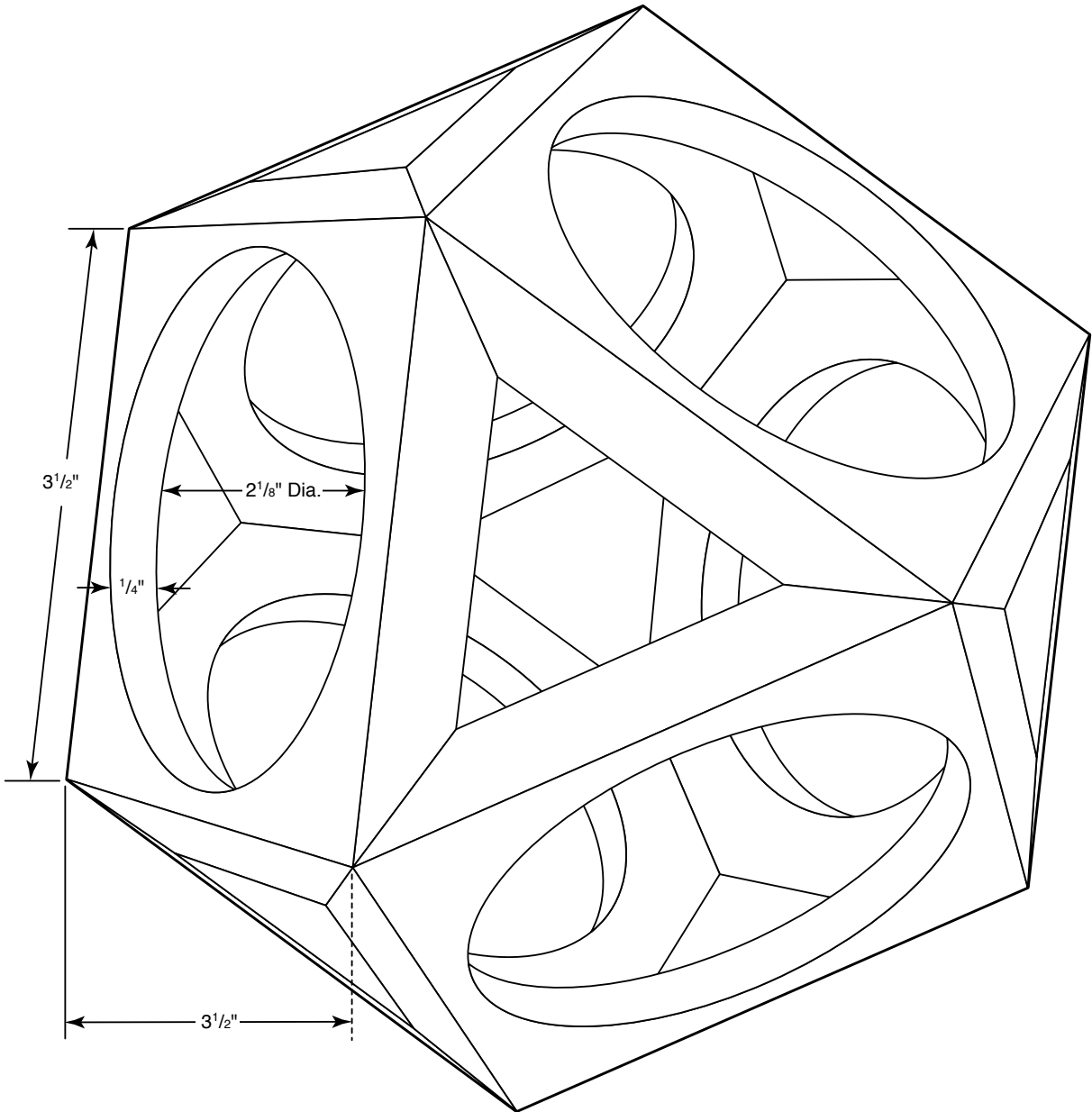

FIG 2.

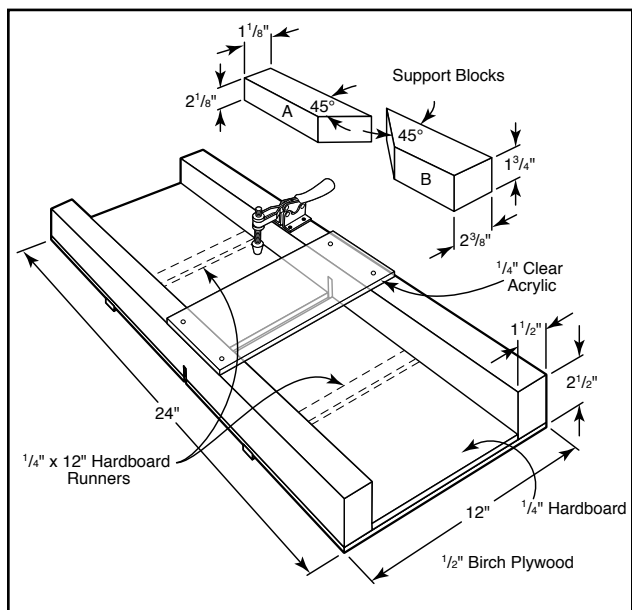

FIG 3.

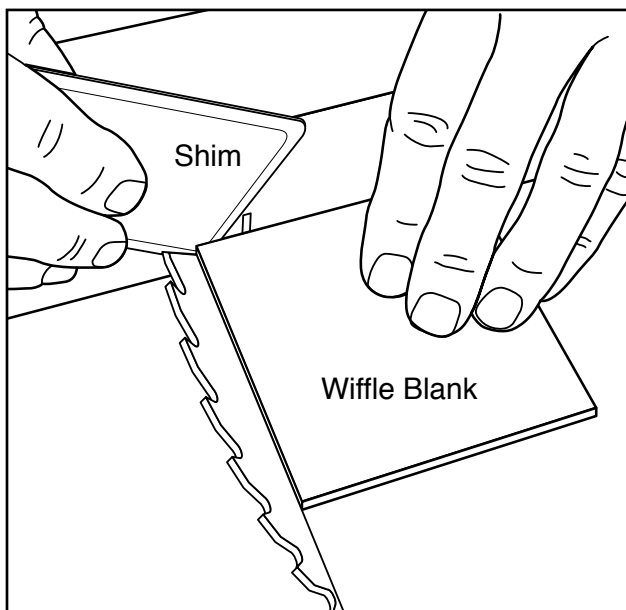

FIG 4.

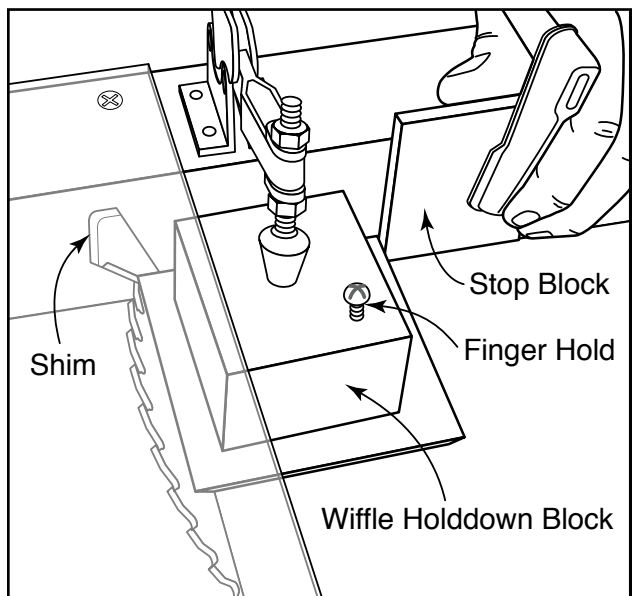

FIG 5.

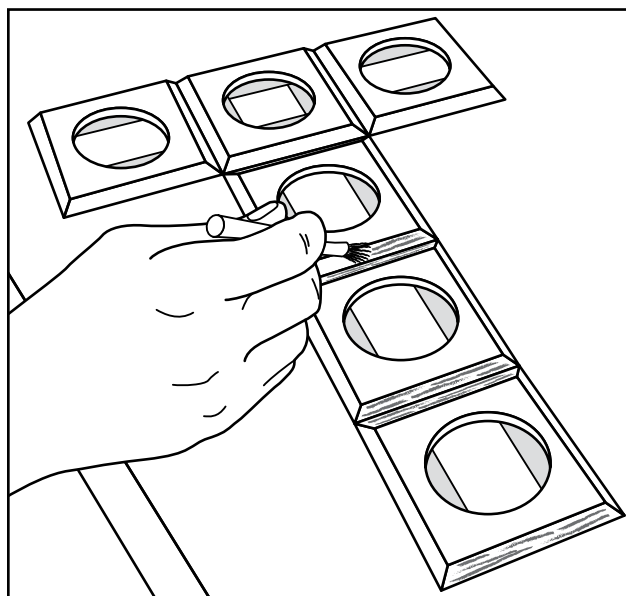

FIG 6.

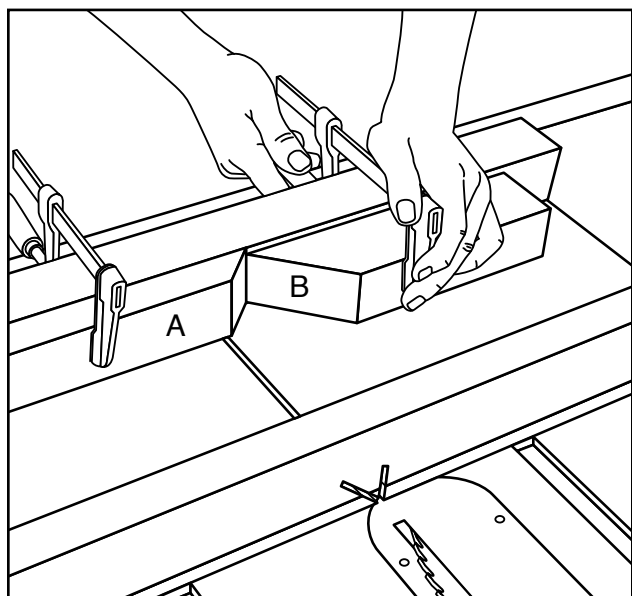

FIG 7.

