

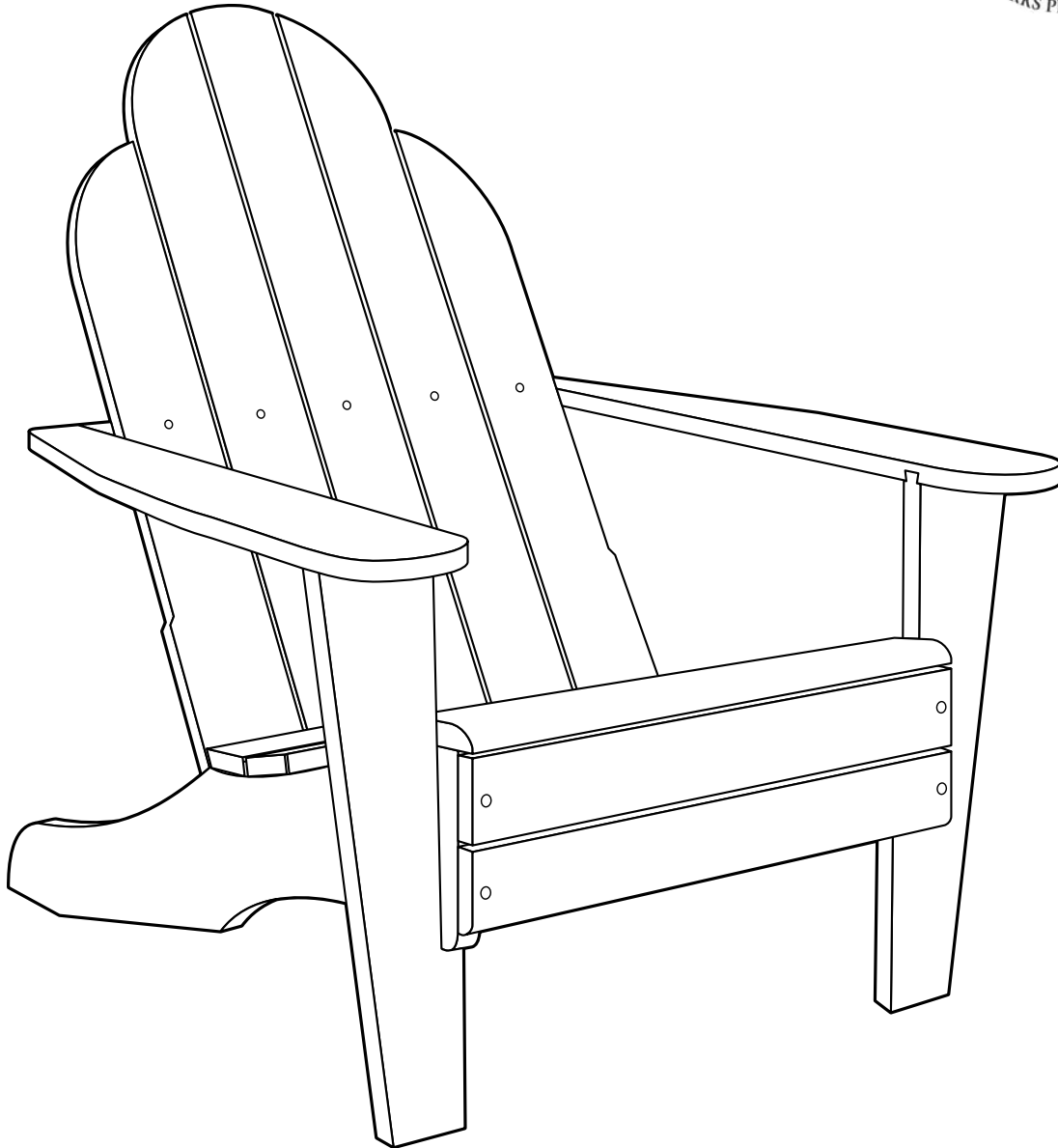

WOODWORKS: ADVANCED PROJECT 2010-2011
ADIRONDACK CHAIR



There may be no outdoor chair more classic and familiar than the one that hails from upstate New York. With its generous proportions and laid-back angles, the Adirondack chair is all about taking it easy. Its sturdy yet straightforward construction makes it a great project for intermediate and advanced woodworkers and even “seasoned” beginners looking to step up their skills in areas such as making and using templates and working with a router. And after you build it, you will learn more about applying and using finishes to protect the wood and keep it looking beautiful.

TOOLS REQUIRED

Hand Tools

- Sanding block
- Back saw
- Pipe clamps
- Rasp
- Wood chisels
- Adjustable square

Power Tools

- Table saw
- Band saw or jigsaw
- Plunge router
- Biscuit joiner
- Drill press, 3/8" plug cutter bit
- Power drill with drill bits, Phillips-head screwdriver bit, 3/8" plug cutter
- Orbital or finish sander

Miscellaneous

- Epoxy or exterior-grade glue
- Tape measure
- Pencil
- Safety glasses
- 120-grit sanding belt
- 120-, 150- and 220-grit sandpaper
- Clean, lint-free cloths
- Respirator
- Gloves for finishing
- Mineral spirits, for oil based waterproofer
- Good quality, natural-bristle brush (for oil based waterproofer) or synthetic-bristle brush (for water-based waterproofer)

SHOPPING LIST

Wood Recommendation: Pressure-treated pine

Alternate Wood: Oak

Part	Qty.	Th. x W x L
A, B	1 @ 8'	1" x 7-1/2"
C	1 @ 2'	1" x 5-1/2"
D, E, F, G	1 @ 8', 1 @ 10'	3/4" x 5-1/2"
H, J, K	1 @ 8', 1 @ 10'	3/4" x 3-1/2"
1/4" dowels	4	
#8 x 2" flathead stainless-steel screws	24	

CUTTING LIST

Overall Dimensions: 30" W x 36" H x 34" D			
Part	Name	Qty.	Th. x W x L
A	Front leg	2	1" x 5-1/2" x 20-3/8"
B	Back leg	2	1" x 7" x 37-1/2"
C	Stretcher	1	1" x 4-1/2" x 19-3/4"
D	Arms	2	3/4" x 5" x 30-3/8"
E	Center back slat	1	3/4" x 4" x 32"
F	Tall back slats	2	3/4" x 4" x 32"
G	Short back slats	2	3/4" x 4-1/4" x 26"
H	Seat slats	8	3/4" x 3" x 21"
J	Back rail	1	3/4" x 3-3/8" x 23"
K	Splines	4	1/4" x 3" x 7/8"

WOOD FINISHING PRODUCTS

Recommended Finish

Thompson's® WaterSeal® Deck & House Oil Waterproofing Stain in Semi-Transparent Colonial Blue

Alternate Finish

Thompson's® WaterSeal® Advanced Wood Protector Natural Cedar

BEFORE YOU BEGIN

Good craftsmanship begins and ends with good work habits, so make the following steps part of your routine workshop practice. If you have any doubts or questions about how to proceed with a project, always discuss them with your shop instructor.

- Carefully and fully review plans and instructions before putting a tool to the project lumber.
- Work sensibly and safely. Wear safety goggles when doing work that creates flying chips and sawdust; wear the appropriate respirator whenever making sawdust or working with thinners or other solvents.
- At the end of every work session, clean up your shop area and put away all portable tools.

CUTTING AND ASSEMBLY PROCEDURE

Make the Templates

1. Templates will make it easy to build more than one chair, now and in the future. They're made from 1/4" hardboard and are used to guide the bearing of a flush-cutting router bit. Figure 2 shows the shapes needed for the back slats (E, F, G). Start with a single 8-3/8" x 26" piece of hardboard. Draw a 6" radius at the top with a compass. Rip the 4" wide center slat template from the right side. Rip the template for the outside slats to 4" but stop about 6" from the bottom. Finish the 1/4" jog as shown with a band saw; cut the top curves and rasp them smooth.

2. Figure 3 shows the remaining templates. The templates for the back legs can be enlarged on a copier to full size. Enlarge the image shown by 200 percent and again by another 200 percent and then one more time by 183 percent. Measure the last enlargement to make sure it matches the dimensions shown. If it doesn't, increase or decrease the final enlargement accordingly. (You can also draw your own layout grid using the scale shown.)

Woodworker's Tip: *To create the notch on the front leg template, raise the blade on the table saw to full height and rip most of the waste. Finish the cut on the band saw. Then use the band saw to taper the front-leg template.*

3. When all the templates are cut, smooth the edges with a rasp or sandpaper wrapped around a curved block. Note that the templates for parts B and D have slots for routing dovetail sockets. You must make an insert piece that fills these slots when using the template with the router or the bit will gouge the workpiece.

Make and Shape the Parts

4. Cut parts A, B, D, E, F and G to their approximate sizes. (The dimensions between long parallel sides can be ripped to their exact measurements.) Use the templates to trace the finished shapes onto the workpieces. Cut away the waste with a band saw to slightly over-size, then adhere the template to the piece with double-sided tape, carefully aligning it with the trace lines.

5. Rout each workpiece by riding the template against the bearing of the flush-cutting router bit (see Fig. 4, showing the technique applied to a back leg, B).

6. Cut parts C, J and H to their specified size. One long edge of one of the seat slats, H, requires a 3/4" radius (see Fig. 1), which can be done on the router table or by hand with a block plane and an orbital sander. Use a table saw to rip the front edge of J, the back rail, to a 58-1/2° angle.

Cut the Joints

7. Rout 3/8" deep dovetail sockets in the arms, D, and back legs, B (see Fig. 5). Set the bit to the depth of the cut plus the thickness of the template.

8. Cut the dovetails in the stretcher, C, and the front legs on the router table, using the same dovetail bit used to make the sockets (see Fig. 6). Attaching a tall fence to the router-table fence will help to stabilize the piece. Round the end of each dovetail by making scoring cuts with a backsaw and then paring to shape with a small chisel (see Fig. 7).

9. Mortise the arms using the plunge router fitted with an edge guide and a 1/4" spiral up-cutting bit. To steady the router, clamp a scrap board to the bench and clamp the arm in the bench vise so its edge is flush with the top of the board. Rout slots for the cross-grain splines, K, in the same manner.

10. Rout the tenons for the back rail, J, by passing it flat over a router bit or dado head. Round the corners with a rasp.

11. Make the splines by rounding the edges of a 1/4" x 3" x 12" board with a rasp so they fit the mortises in the back slats. Cut four 7/8" splines on the table saw.

12. Use a biscuit joiner to cut the slots in the bottom of the back slats and into the stretcher. You can also groove the parts on the table saw and join the back slats to the stretcher with a 1/4" thick spline.

Assemble the Chair

13. First join the back legs, B, to the stretcher, C, then the arms, D, to the front legs, A. Connect the back rail, J, to the arm/front leg assembly. The best material for bonding these joints is epoxy, but exterior-grade glues will also work.

14. Use scrap sticks to support the arms while you screw the back legs to the front legs. Notches cut into the tops of the sticks will help hold the back of the arms level with the fronts during assembly. When drilling for screws, first drill a 3/8" x 1/4" deep hole so the screw heads will be recessed and later covered with a wood plug.

15. Pull the arms tight to the back rail with a pipe clamp, then drill and peg the four joints with 1/4" dowel pins (see Fig. 1).

16. With the back rail in position, hold a back slat against the rail and mark it for the counterbored screw hole (see Fig. 8), using an adjustable square held against the back rail. Run the line from the side of the slat to the front. Transfer this mark to the other slats. Because the screws go in at an angle, this mark has to coincide with the top of the back rail.

17. Epoxy the splines, K, into the back slats using 1/8" thick scrap to create the correct gaps. Use a minimal amount of epoxy so that there is little or no squeeze-out, which can be difficult to remove.

18. Align the tops and bottoms of the slats and clamp them together with one pipe clamp set along the line of the splines.

19. Epoxy the biscuits into the stretcher, then set the entire slat assembly onto the stretcher. When the slats are properly positioned, screw them to the back rail.

20. Install the seat slats using 1/8" spacers and woodscrews counter-bored into the ends. Work from front to back, with the first two slats being installed as shown in Fig. 1.

21. Make the 3/8" x 1/4" plugs needed to fill the screw holes. Apply a dab of glue to the bottom face and insert them into the holes. When the glue is dry, cut the plugs flush with the surface using a wood chisel.

Woodworker's Tip: For the best appearance, the grain of the screw plugs should be aligned with that of the surrounding wood.

22. In preparation for finishing, sand all surfaces with 120-grit sandpaper.

PROTECTING YOUR PROJECT

Any type of wood that's used outdoors needs protection from water damage. There are a variety of protective coatings available, including clear and tinted wood protectors and semi-transparent and solid stains. Each of these finishes has a different look and maintenance requirement.

To provide complete protection for your project, use Thompson's® WaterSeal® Deck & House Oil Waterproofing Stain or Thompson's® WaterSeal® Advanced Wood Protector. Both products not only prevent water damage, but also resist damage from mildew and ultraviolet radiation in sunlight (UV), and they exceed industry standards for waterproofing on wood. Plus, the semi-transparent color will give plain pine just the right amount of rich wood-tone. This stain is available in over 100 beautiful colors.

Woodworker's Tip: Always be sure to choose a waterproofer that claims to exceed industry standards for waterproofing on wood.

FINISHING TIPS

- Coverage: The approximate coverage of Thompson's® WaterSeal® Deck & House Oil Waterproofing Stain or Thompson's® WaterSeal® Advanced Wood Protector on pine is 250 square feet per gallon.
- When you apply Thompson's® WaterSeal® Deck & House Oil Waterproofing Stain or Thompson's® WaterSeal® Advanced Wood Protector, do not mix it with other waterproofing products, because variations in the final appearance of the surface being treated may result. Also, do not thin these products.

Recommended Finish

23. Before applying Thompson's® WaterSeal® Deck & House Oil Waterproofing Stain, the wood surface must be free of all dirt, wood dust and all other contaminants. If the wood needs cleaning, use Thompson's® WaterSeal® Deck Cleaner & Brightener or Thompson's® WaterSeal® Deck Wash. Read and follow the directions found on the back of the package. After the cleaning is done, read and follow the

directions found on the back of the can of stain. Then do a trial test before full application. The surface may darken slightly with application and color appearance is different when the wood is fully dry.

24. When applying this product, do not use it with other waterproofing or stain products, as variations in final appearance of the wood may result. Do not thin. To ensure good penetration, do not apply in direct sunlight or on hot days. Do not apply if rain is expected within 24 hours. Also, temperature must be above 50° F. and remain above freezing for 24 hours.

25. Shake or stir contents for a minimum of 2 minutes before use. Intermix all containers (of the same color) to be used to assure color uniformity.

26. Apply using a paint pad or brush. Do not apply using a roller. For small projects, a brush is the preferred applicator.

27. In most applications, only one light coat is necessary. Apply with a brush or applicator pad. Regardless of which application method is used, remove excess within 15 minutes by redistributing it to drier areas or wiping it off. Stain will dry in 4 hours. A second coat can be added, if desired, after 4 hours.

28. Brushes and equipment used for water-based products must be cleaned with soap and water.

Alternate Finish

29. Before applying Thompson's® WaterSeal® Advanced Wood Protector Natural Cedar, read and follow the directions found on the back of the package. Be sure that both surface and air temperature are above 50° F. during application and for 48 hours after application. And, if you're working outside, do not apply product if rain is forecasted within 24 hours of application.

30. The surfaces must be free of all dirt, wood dust and all other contaminants. This product can be applied to damp, freshly cleaned wood. To clean the wood, use either Thompson's® WaterSeal® Deck Cleaner & Brightener or Thompson's® WaterSeal® Deck Wash.

31. Do not mix the product with other waterproofing products because variations in the final appearance of the surface being treated may result.

32. Before applying the product over the entire surface, a small trial patch is recommended.

33. Apply only one thin, even coat. DO NOT APPLY A SECOND COAT. A heavier or additional coat will not improve performance or appearance. Avoid puddling. Tackiness will result if overapplied. Tackiness may also occur after application if overnight temperature falls below 50°F. within 48 hours of application. Drying time will vary depending on wood surface and humidity. Allow a minimum of 12 hours before using the bench.

34. Allow at least 12 hours to dry before you use the chair.

35. Clean brushes and equipment with soap and water, then rinse with clean water.

NOTE: The length of protection will vary depending on environment. Perform the following splash test once a year to see whether reapplication is necessary. Sprinkle water on various sections of surface to be sealed. If water absorbs and darkens color of substrate within 5 seconds, the surface is porous and considered ready to be treated. If water beads up or otherwise sits on top of surface, then surface doesn't need protection at this time. For maximum protection from color change and other damage caused by the sun, reapplication is recommended every year. Vertical and horizontal surfaces will experience color changes at different rates.

PRODUCT SAFETY

For your safety and the safety of those you work with, always read the safety warnings, which manufacturers print on their labels, and follow them to the letter. Typical safety advice and instructions will contain information such as the following:

WARNING! Removal of old paint by sanding, scraping or other means may generate dust or fumes that contain lead. Exposure to lead dust or fumes may cause brain damage or other adverse health effects, especially in children or pregnant women. Controlling exposure to lead or other hazardous substances requires the use of proper protective equipment, such as properly fitted respirator (NIOSH approved) and proper containment and cleanup. For more information, call the National Lead Information Center at 1-800-424-LEAD (in US) or contact your local health authority.

Contents are **COMBUSTIBLE**. Keep away from heat and open flame.

Contains **ALIPHATIC HYDROCARBONS**.

VAPOR HARMFUL. Use Only With Adequate Ventilation. To avoid overexposure, open windows and doors or use other means to ensure fresh air entry during application and drying. If you experience eye watering, headaches, or dizziness, increase fresh air supply or wear respiratory protection (NIOSH/MSHATC23C or equivalent), or leave the area. Avoid contact with eyes and skin. Wash hands after using. Keep container closed when not in use. Do not transfer contents to other containers for storage.

FIRST AID: In case of eye contact, flush thoroughly with large amounts of water for 15 minutes and get medical attention. For skin contact, wash thoroughly with soap and water. In case of respiratory difficulty, provide fresh air and call physician. If swallowed, get medical attention immediately.

DELAYED EFFECTS FROM LONG-TERM OVEREXPOSURE.

Contains solvents which can cause permanent brain and nervous system damage. Intentional misuse by deliberately concentrating and inhaling contents may be harmful or fatal.

WARNING: This product contains a chemical known to the State of California to cause cancer and birth defects or other reproductive harm.

DO NOT TAKE INTERNALLY. KEEP OUT OF REACH OF CHILDREN.

SAFE DISPOSAL OF RAGS AND WASTE.

DANGER: Rags, steel wool, other waste soaked with this product, and sanding residue may spontaneously catch fire if improperly discarded. Immediately place rags, steel wool, other waste soaked with this product, and sanding residue in a sealed, water-filled metal container. Dispose of in accordance with local fire regulations.

This project originally appeared in *American Woodworker* magazine, June 2001, page 60.

American.
Woodworker

FIG 1.

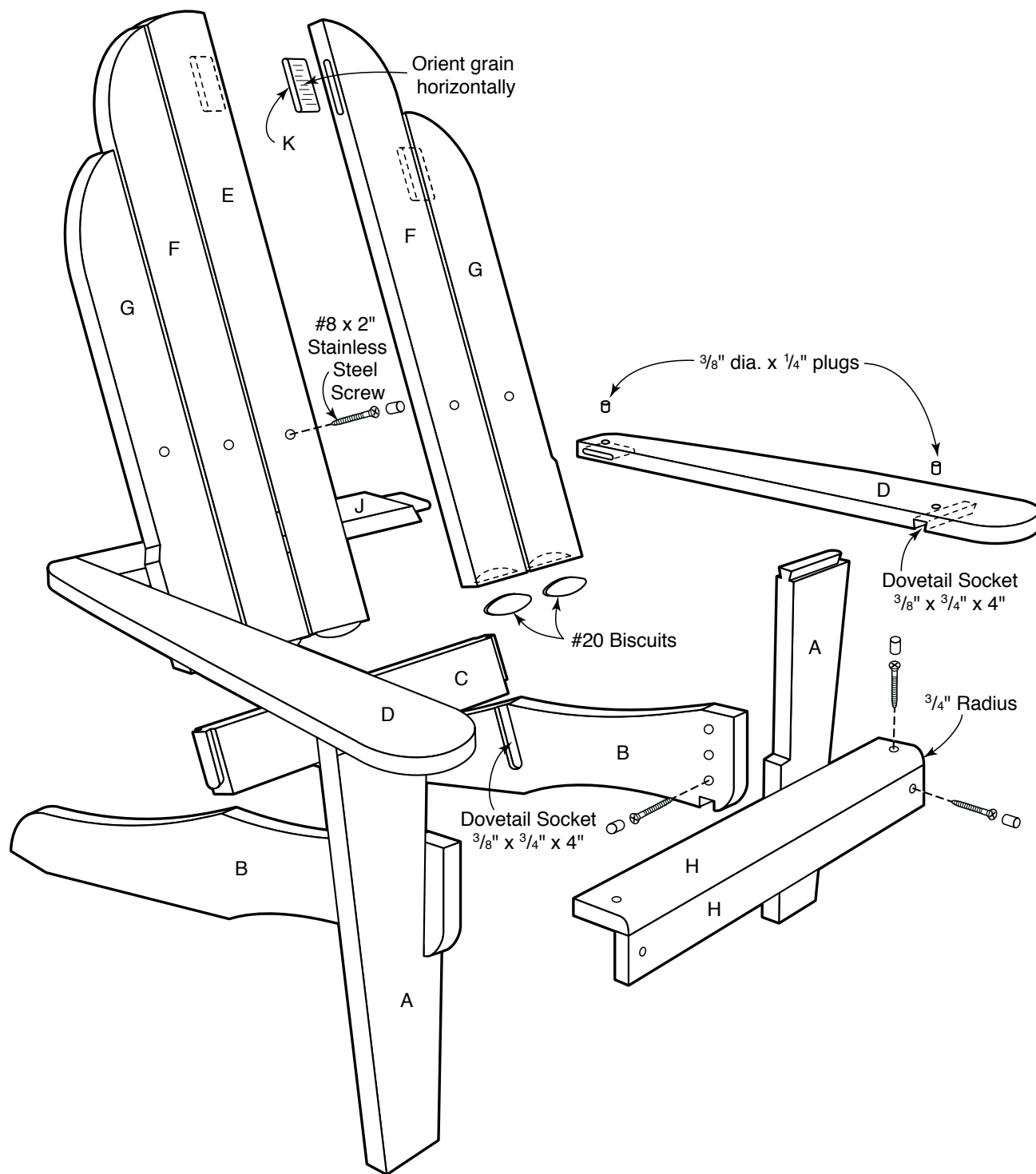

FIG 2.

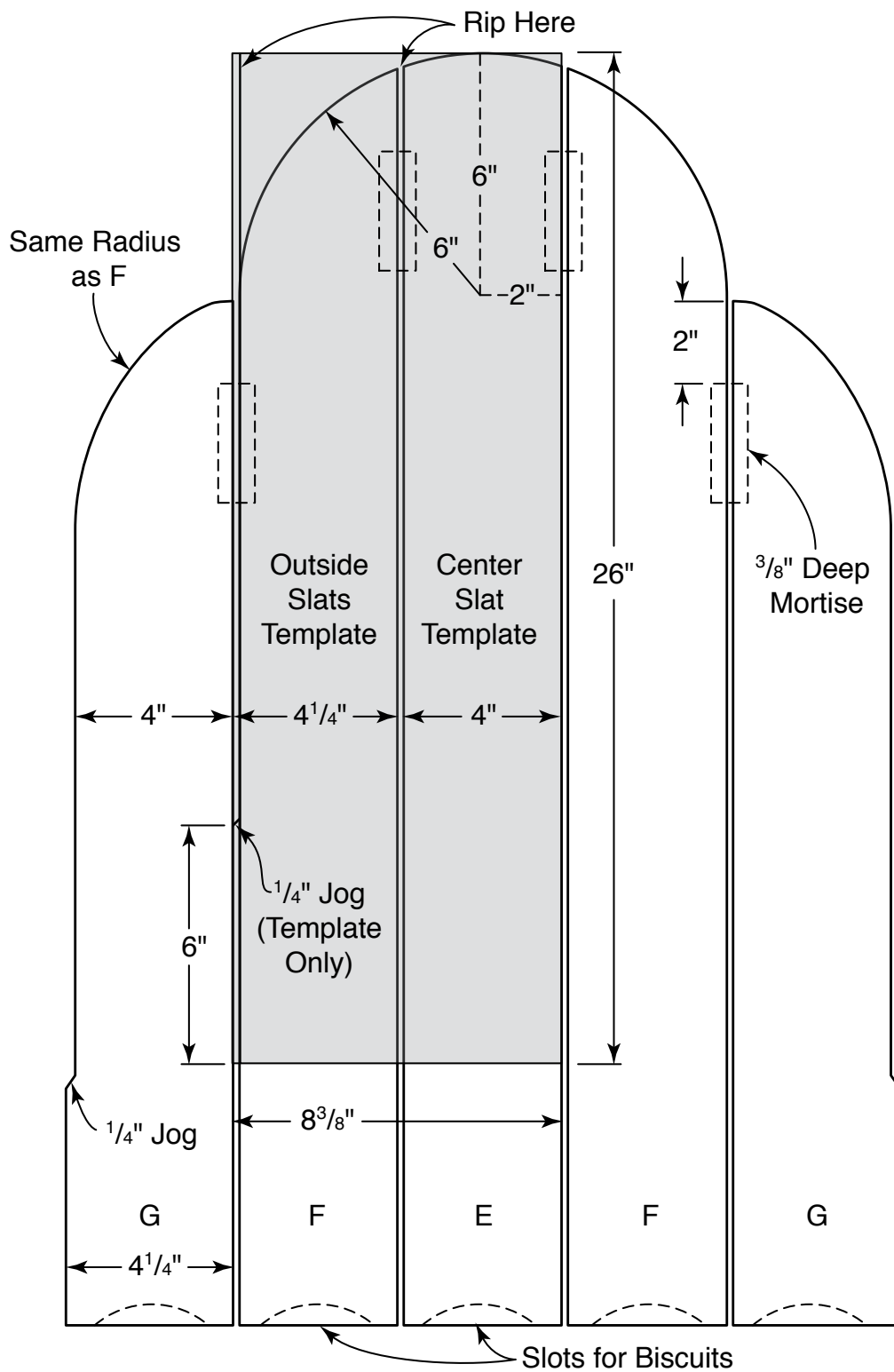

FIG 3.

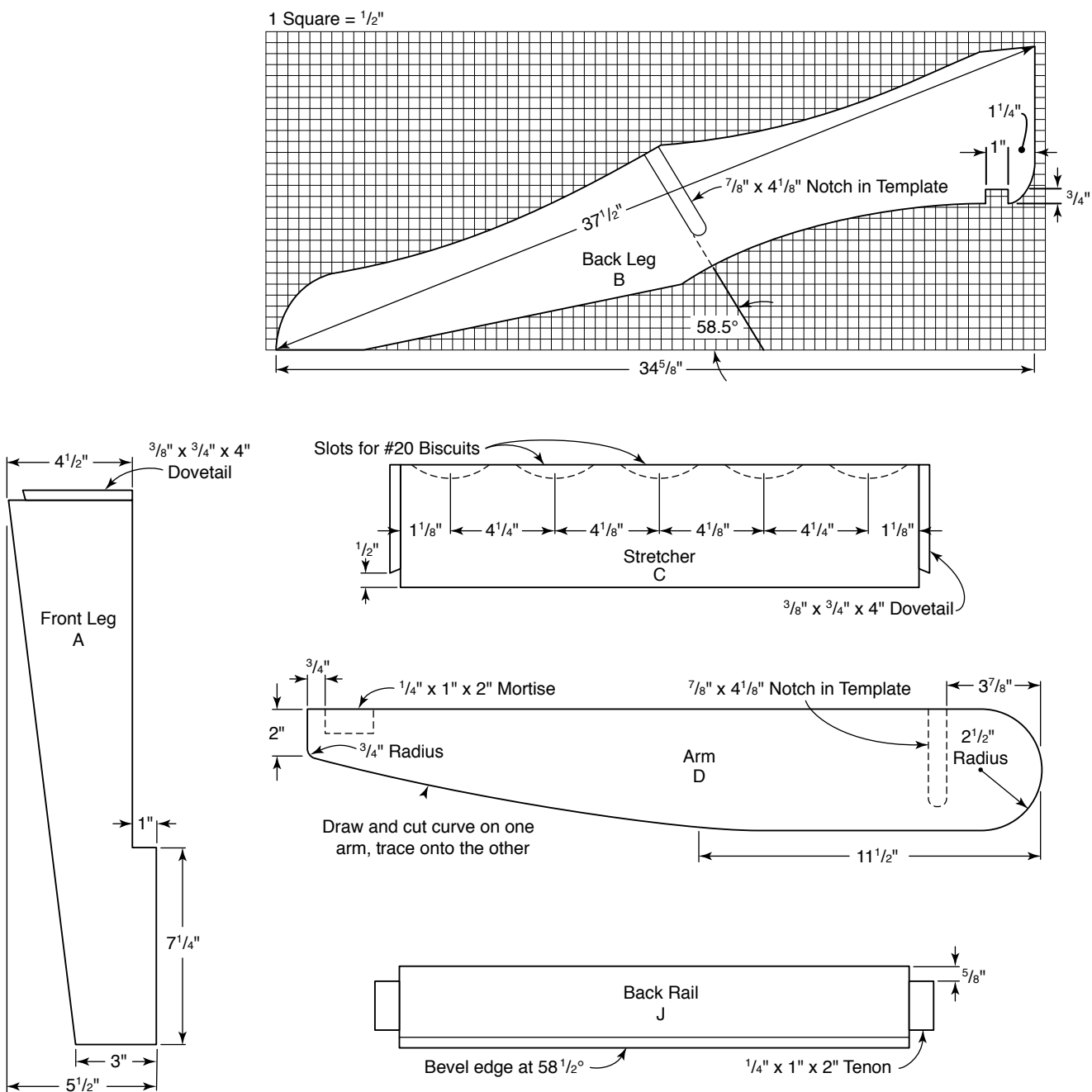

FIG 4.

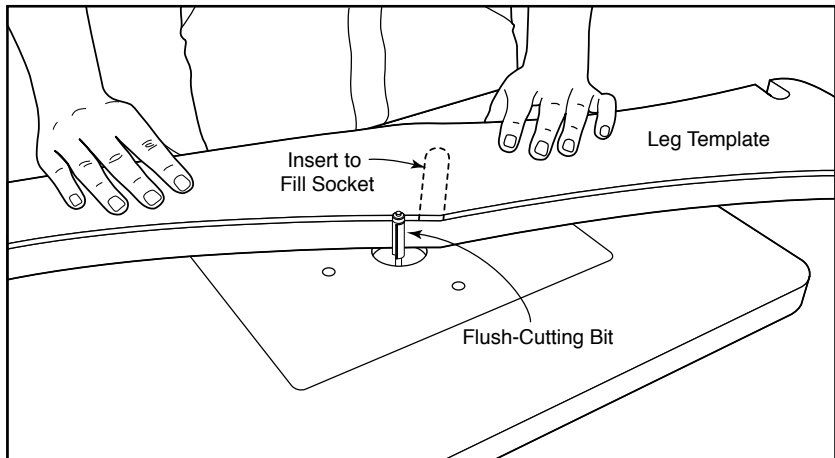

FIG 5.

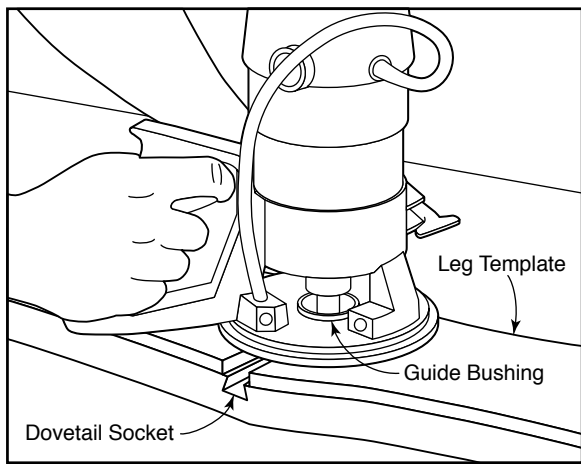

FIG 6.

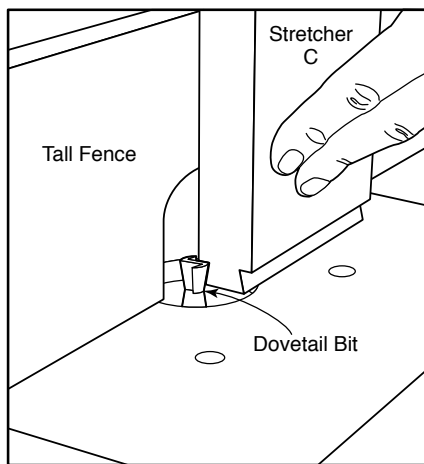

FIG 7.

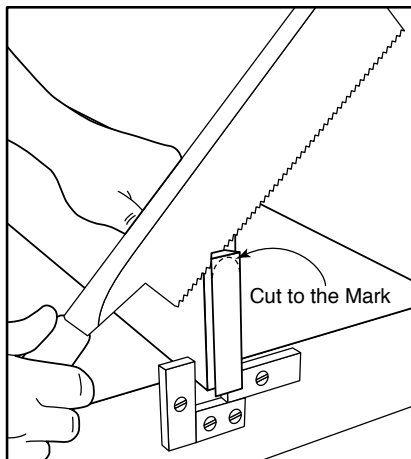

FIG 8.

