

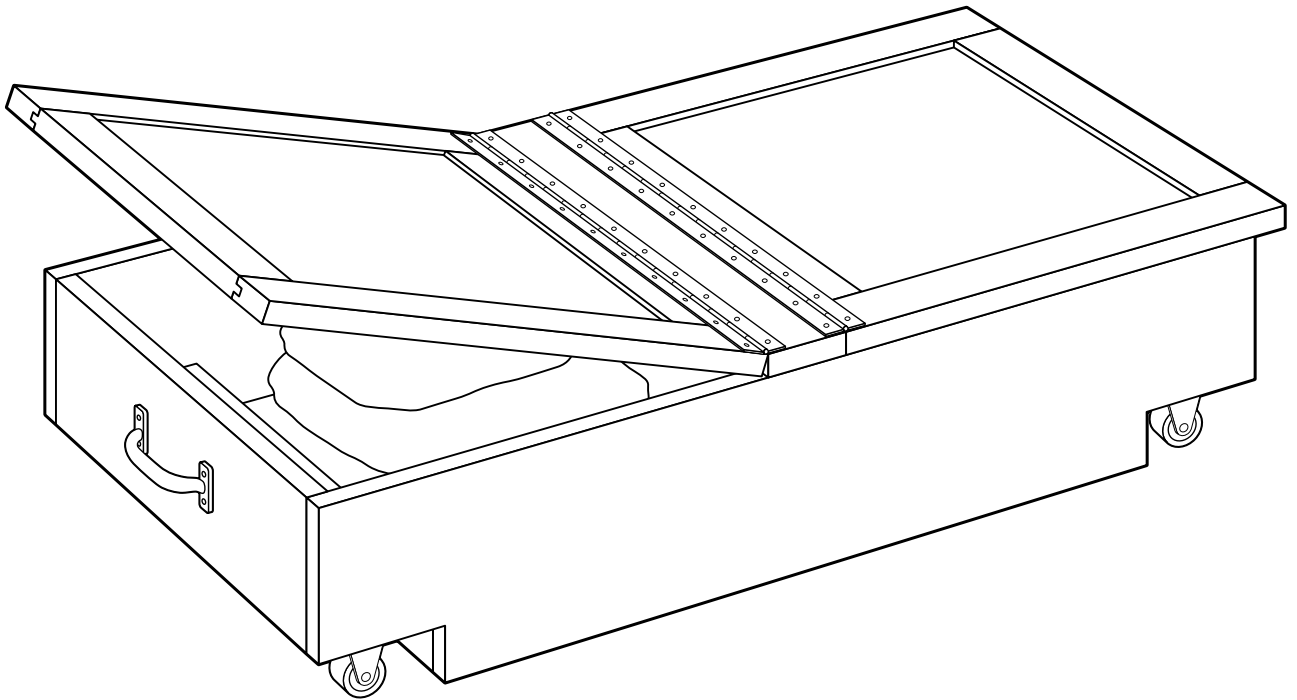

WOODWORKS: ADVANCED PROJECT 2010-2011
HIDEAWAY LOCKER



If your stuff is spread all over and there's just no place to put it, you must need more storage. How about the space under your bed? This hideaway locker is the right way to do it! Designed to roll easily under a bed, to make the most of an underutilized storage space. Made from solid oak and oak plywood, this project will give advanced woodworkers more practice in the art of biscuit joinery and in making the stile-and-rail, recessed-panel lids that adorn the top. And after you build it, you will learn more about applying and using finishes to protect the wood and keep it looking beautiful.

TOOLS REQUIRED

Hand Tools

- Sanding block
- Pipe or bar clamps
- Adjustable square

Power Tools

- Shaper or router table with tongue-and-groove cutter
- Biscuit joiner
- Table saw
- Miter saw
- Power drill with drill bits, Phillips-head screwdriver bit
- Orbital or finish sander

Miscellaneous

- Safety glasses
- 120-grit sanding belt
- 120-, 150- and 220-grit sandpaper
- Carpenter's glue
- Clean, lint-free cloths
- Respirator
- Gloves for finishing
- Mineral spirits, for cleanup of oil based finishes
- Good quality, natural-bristle brush (for oil based finishes)

SHOPPING LIST

Wood Recommendation: Red or White Oak

Alternate Wood: Pine

Part	Qty.	Th. x W x L
A, B, C, E, F, G, H	1	1x8x8'
	1	1x8x9'
D	1/4-sheet	3/4" oak plywood
J	1/4-sheet	1/4" oak plywood
Casters	4	2" fixed wheel, plate mount
Hinges	36" cut into two hinges	2" brass piano or continuous
Handle	1	5" to 6" brass utility

CUTTING LIST

Overall Dimensions: 36" W x 8" H x 18" D				
Part	Name	Qty.	Material	Th. x W x L
A	Sides	2	Solid oak	3/4" x 6-1/2" x 36"
B	Caster supports	2	Solid oak	3/4" x 4-1/2" x 16-1/2"
C	Spacers	2	Solid oak	3/4" x 1-3/4" x 16-1/2"
D	Bottom	1	Oak ply	3/4" x 16-1/2" x 25-1/2"
E	Ends	2	Solid oak	3/4" x 4-3/4" x 16-1/2"
F	Hinge board	1	Solid oak	3/4" x 3" x 18"
G	Lid stiles	4	Solid oak	3/4" x 2" x 17-3/4"
H	Lid rails	4	Solid oak	3/4" x 2" x 14-3/4"
J	Lid panels	2	Oak ply	1/4" x 14-11/16" x 14-7/16"

WOOD FINISHING PRODUCTS

Recommended Finish

Prep: Minwax® oil based Pre-Stain Wood Conditioner
 Stain/Finish: Minwax® Polyshades® Mission Oak Gloss

Alternate Finish

Prep: Minwax® oil based Pre-Stain Wood Conditioner
 Stain: Minwax® Wood Finish Sedona Red
 Finish: Minwax® Clear Brushing Lacquer Semi-Gloss

BEFORE YOU BEGIN

Good craftsmanship begins and ends with good work habits, so make the following steps part of your routine workshop practice. If you have any doubts or questions about how to proceed with a project, always discuss them with your shop instructor.

- Carefully and fully review plans and instructions before putting a tool to the project lumber.
- Work sensibly and safely. Wear safety goggles when doing work that creates flying chips and sawdust; wear the appropriate respirator whenever making sawdust or working with thinners or other solvents.
- At the end of every work session, clean up your shop area and put away all portable tools.

CUTTING AND ASSEMBLY PROCEDURE

1. Cut the sides (A) to size. Cut 1-3/4" x 4-1/2" notches in the ends of both pieces as shown in Fig. 1.
2. Cut the caster supports (B), the spacers (C) and the ends (E) 1/2" longer than specified and to their exact, specified width. Lay out and cut biscuit slots for joining these three pieces. Glue them all together using short bar or pipe clamps, assuring that all the joints are dead square.
3. When the glue is set on the two BCE assemblies, cut them to their final length on a miter saw, as shown in Fig. 2.
4. Mark biscuit locations on the sides (A) and in corresponding locations in the ends of B and E. Cut all the biscuit slots.
5. Dry-assemble the frame assembly (BCE and A) with clamps and measure for the bottom (D) as shown in Fig. 3. Cut the bottom to size.
6. Lay out and cut biscuit slots into the bottom and into corresponding locations on the frame pieces (BCE and A), as shown in Fig. 4.
7. Assemble the BCE assemblies to the bottom; then join the front and back pieces (A) to this assembly. With a glue-up like this, the more clamps you use, the better. Nine clamps running side to side will ensure tight joints from end to end.
8. Cut the hinge board (F) to the exact dimension of the assembled frame. Use glue and brads to fasten it to the exact middle of the frame.
9. Cut the lid stiles (G) to their specified width and length. This length will allow the lids to overhang the ends by about 1-1/4" to make for easy lifting. Cut the lid rails (H) to their specified width and length. This length will allow for 3/8" tongues for joining to the stiles.
10. Set up a tongue-and-groove cutter on a router or shaper table, as shown in Fig. 5, or however you prefer to machine the lid stiles and rails. This can also be done with a table saw equipped with a dado blade set up for a 1/4" cut.
11. Machine the stiles and rails and dry-assemble them to determine the size of the lid panels (J). For both the length and width, be sure to allow for about 1/8" of play inside the stile-rail frame.

12. Cut the lid panels (J) to size. Assemble the lids with glue and clamps.

13. Screw the casters to the underside of the case ends. Use a square to ensure that they are perpendicular to the ends, as shown in Fig. 6.

14. Center a handle on one end and screw it in place.

15. Screw hinges to the lids and the hinge board.

16. Prior to finishing, remove the lids, hinges, casters and pull. Sand or roundover all the sharp edges with a router.

FINISHING TIPS

- Test the stains and finishes you are planning to use on scraps of wood. On the back of the scrap, mark the stain/finish combination and the type of wood. Allow all samples to dry thoroughly before making your final finish selection. Save your samples for quick reference on future projects.
- All stains and finishes must be allowed to dry thoroughly between coats. Remember that drying times can vary due to humidity and other climatic conditions.
- If you have some leftover stain or finish, wipe the can rim so that stain or finish in the rim won't dry out and prevent the lid from forming a tight seal.
- Brushes used for oil based finishes must be cleaned with mineral spirits.

17. Finish-sand any remaining rough spots with 220-grit sandpaper. Dust off the piece and wipe it carefully with a clean, lint-free cloth lightly dampened with mineral spirits.

Recommended Finish

18. Before applying Minwax® Polyshades® to a softwood such as pine, apply Minwax® oil based Pre-Stain Wood Conditioner, following the directions on the can. Applying it will help to ensure even absorption of stain and prevent blotchiness that can occur.

19. Apply Minwax® Polyshades® following the directions on the can. Use a good quality, natural-bristle brush suitable for use with polyurethane. Stir the can contents thoroughly before starting and periodically repeat stirring during your work session. Allow the first coat to dry at least 6 hours.

20. For the second coat, sand all surfaces lightly with 220-grit sandpaper or very fine (000) steel wool using with-the-grain strokes. Dust off and wipe all surfaces with a cloth dampened with mineral spirits. Apply a second coat of Polyshades® and set the rack aside to cure overnight. To achieve a deeper color, you may apply a third coat after 4 to 6 hours, repeating the application directions. Allow the finish to cure for several days before installing the hardware and using the hideaway locker.

Woodworker's Tip: *If you achieve the desired color on the first or second coats of Polyshades®, apply a clear coat of Minwax® Fast-Drying Polyurethane or Minwax® Wipe-On Poly for added protection.*

Alternate Finish

21. Before applying Minwax® Wood Finish™ to a softwood such as pine, apply Minwax® oil based Pre-Stain Wood Conditioner, following the directions on the can. Applying a pre-stain conditioner will help ensure even absorption of stain and prevent blotchiness.

22. Apply the Minwax® Wood Finish™ you've chosen using a natural-bristle brush and a clean, lint-free cloth, following the directions on the can. The brush will help you get the stain into the inside corners. Allow the Wood Finish™ to set for about 5 to 15 minutes, then wipe off any excess. To achieve a deeper color, you may apply a second coat after 4 to 6 hours, repeating the application directions for the first coat. Allow the stain to dry for 24 hours before applying the protective clear finish.

***Woodworker's Tip:** When wiping off stain, make certain that your last wipe with the cloth goes with the grain of the wood. This way, any stain you might miss during wipe-off will be visually minimized by the wood grain.*

Applying Clear Brushing Lacquer

23. Apply Minwax® Lacquer Sanding Sealer if desired, following label directions.

24. Stir Minwax® Clear Brushing Lacquer well before and during use to rotate the product from the bottom to the top of the can. NEVER SHAKE.

25. Apply a coat of lacquer using a high-quality, natural or synthetic-bristle brush. Apply sufficient lacquer to seal open joints, edges and end grain.

26. Let the first coat dry at least 2 hours, then apply a second coat.

27. Apply a third coat, repeating the steps above for each coat. Apply a fourth coat, if desired.

28. After the final coat, allow at least 24 hours before installing the hardware and using the hideaway locker.

PRODUCT SAFETY

For your safety and the safety of those you work with, always read the safety warnings, which manufacturers print on their labels, and follow them to the letter.

WARNING! Removal of old paint by sanding, scraping or other means may generate dust or fumes that contain lead. Exposure to lead dust or fumes may cause brain damage or other adverse health effects, especially in children or pregnant women. Controlling exposure to lead or other hazardous substances requires the use of proper protective equipment, such as properly fitted respirator (NIOSH approved) and proper containment and cleanup. For more information, call the National Lead Information Center at 1-800-424-LEAD (in U.S.) or contact your local health authority.

DANGER: Rags, steel wool, other waste soaked with oil based stains and clear finishes, and sanding residue may spontaneously catch fire if improperly discarded. Immediately place rags, steel wool, other waste

soaked with this product, and sanding residue in a sealed, water-filled metal container. Dispose of in accordance with local fire regulations.

CAUTIONS: CONTAINS ALIPHATIC HYDROCARBONS.

Contents are **COMBUSTIBLE**. Keep away from heat and open flame. **VAPOR HARMFUL**. Use only with adequate ventilation. To avoid overexposure, open windows and doors or use other means to ensure fresh air entry during application and drying. If you experience eye watering, headaches, or dizziness, increase fresh air, or wear respiratory protection (NIOSH approved), or leave the area. Avoid contact with eyes and skin. Wash hands after using. Keep container closed when not in use. Do not transfer contents to other containers for storage.

FIRST AID: In case of eye contact, flush thoroughly with large amounts of water for 15 minutes and get medical attention. For skin contact, wash thoroughly with soap and water. In case of respiratory difficulty, provide fresh air and call physician. If swallowed, call Poison Control Center, hospital emergency room, or physician immediately.

DELAYED EFFECTS FROM LONG-TERM OVEREXPOSURE.

Contains solvents, which can cause permanent brain and nervous system damage. Intentional misuse by deliberately concentrating and inhaling contents may be harmful or fatal.

WARNING: This product contains a chemical known to the State of California to cause cancer and birth defects or other reproductive harm.

DO NOT TAKE INTERNALLY. KEEP OUT OF REACH OF CHILDREN. CONFORMS TO ASTM D-4326. Contact a physician for more health information.

FIG 1.

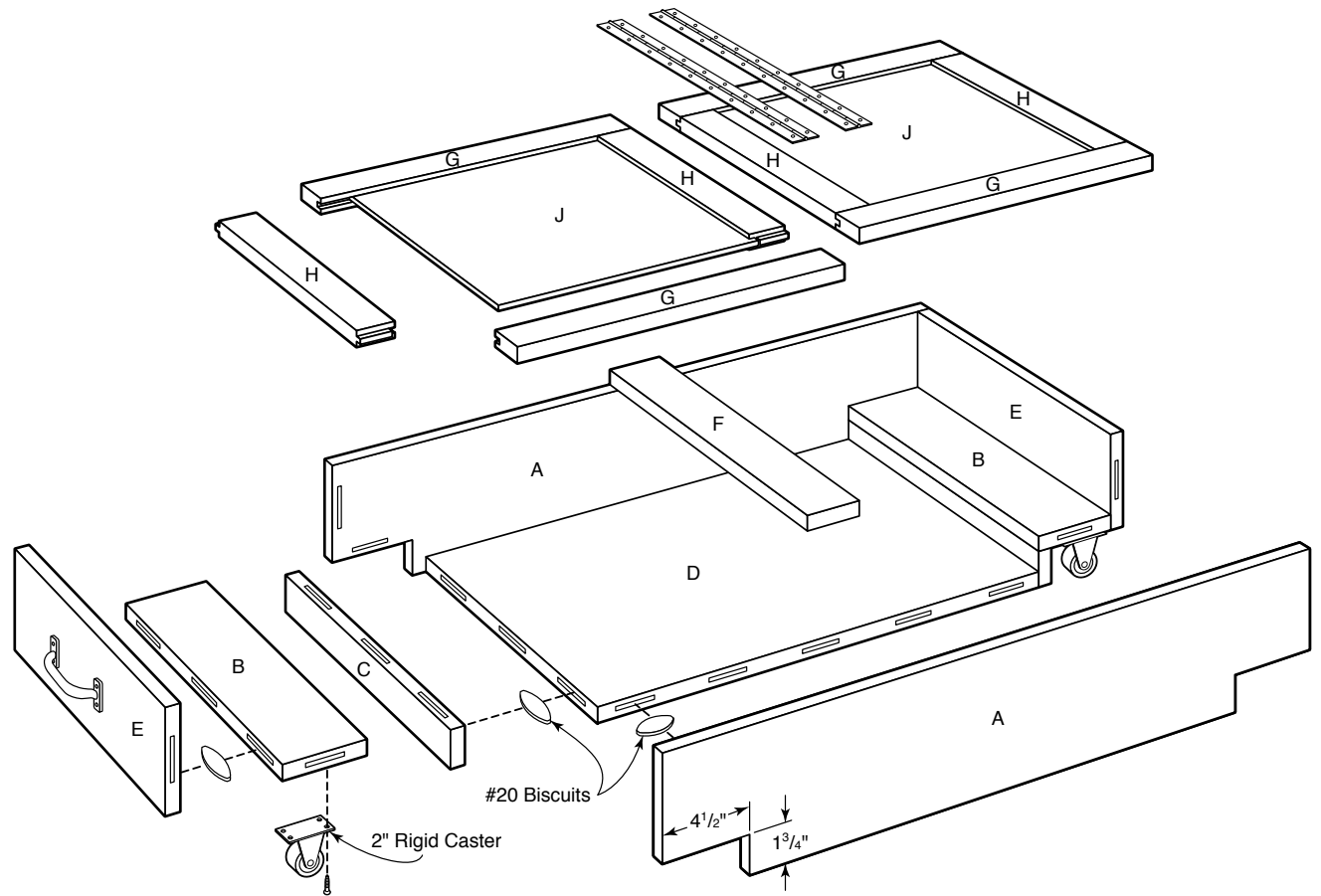

FIG 2.

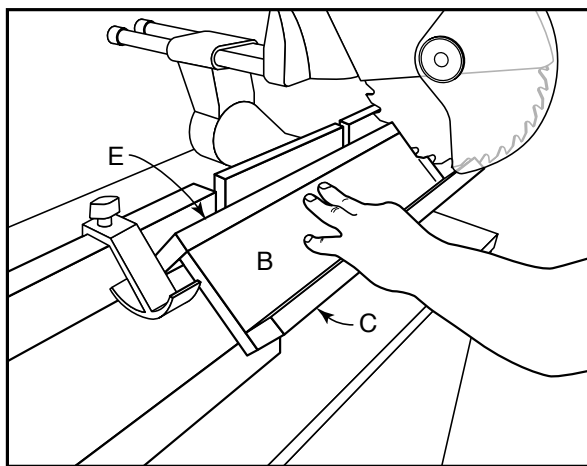

FIG 3.

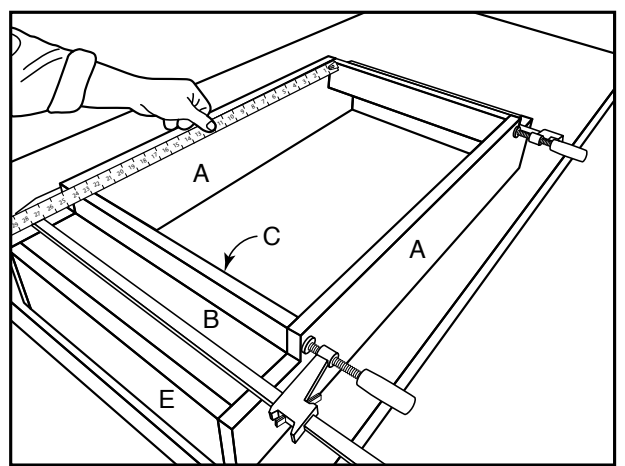

FIG 4.

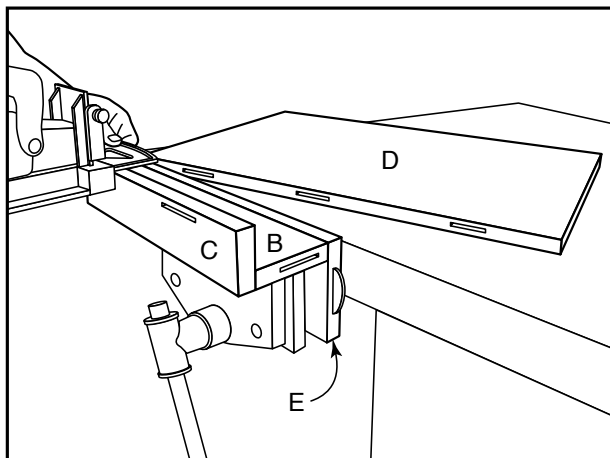

FIG 5.

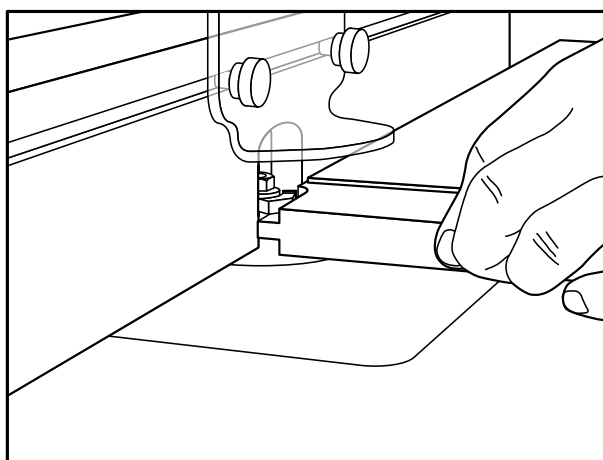
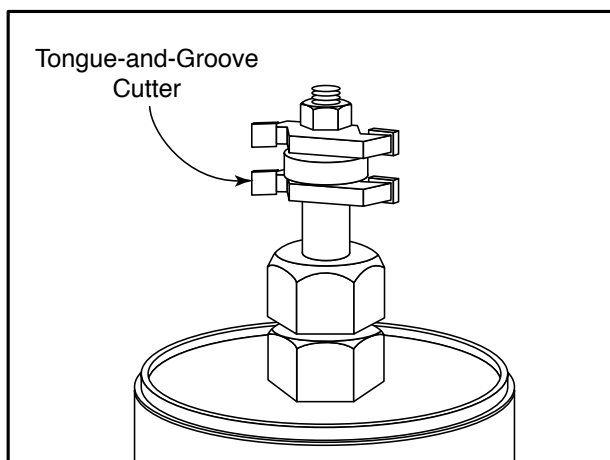

FIG 6.

