

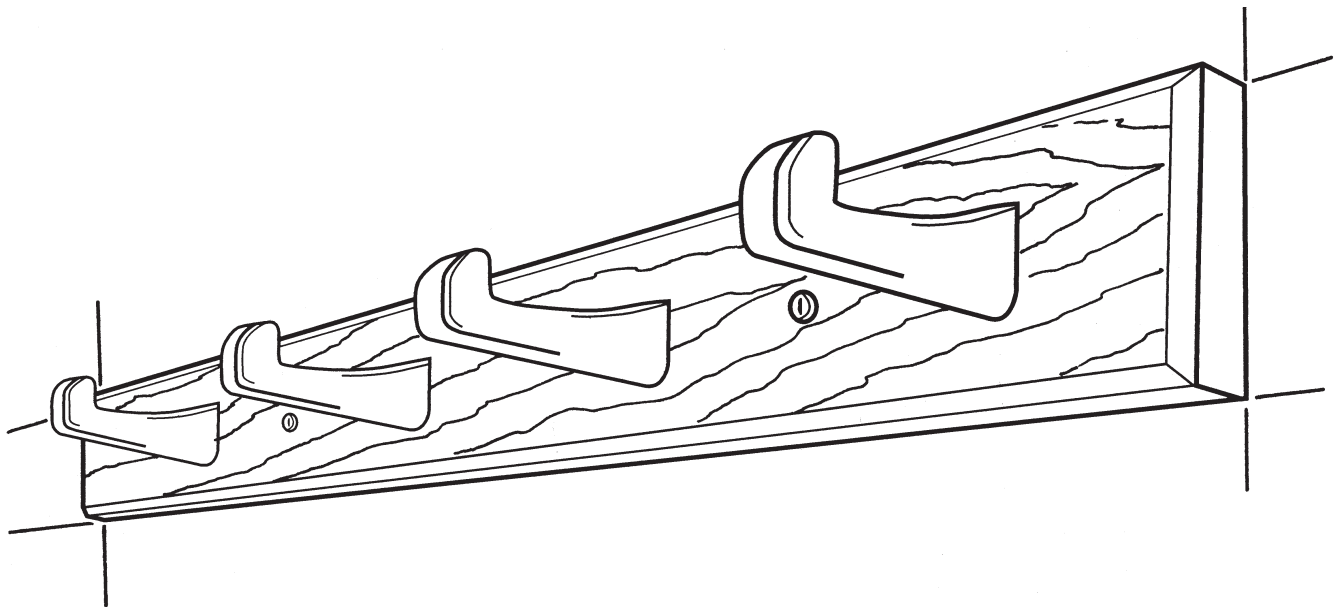

**WOODWORKS: BEGINNER PROJECT**  
**WHITTLED PEG RACK**



Historically, peg racks like this one were hidden. They were fastened to the back walls of wardrobes in the days before wire coat hangers were invented. But this one's too nice to hide!

- You can adjust the length of your peg rack to fit any wall, and you can mount as many or as few pegs as you like. They don't all have to look alike, either. As your whittling technique improves, the pegs will become more consistent.

This project gives beginning woodworking students the opportunity to develop their whittling skills while doing some basic measuring, cutting, drilling and assembling to produce a great-looking household necessity. If you haven't done it much before, you'll find that whittling is relaxing and enjoyable, not to mention a nice break from machine work. You can also choose to cut the pegs with a scrollsaw to get some practice on that machine. And after you build the piece, you'll learn how to apply and use finishes to protect the wood and keep it looking beautiful.

## TOOLS REQUIRED

### Hand Tools

- Whittling knife
- Block plane

### Power Tools

- Drill or drill press with 1/2" drill bit
- Table saw
- Scrollsaw, stationary belt and drum sanders (for machine-made pegs)

### Miscellaneous

- Pencil
- Safety glasses
- Carpenter's glue
- Sandpaper
- Clean, lint-free cloths
- Small square
- Woodcarver's glove
- Leather thumb guard

- Fine (000) steel wool (for Polyshades®)
- Respirator
- Gloves for finishing
- Mineral spirits
- Water-filled metal container with tight-fitting lid
- Minwax® Wood Finish™ Stain Brush

## SHOPPING LIST

1x4 pine or other softwood (whittled pegs) or oak or other hardwood (machine-cut pegs). For a 4-peg rack, the backboard will be 20" long. For a longer rack, keep in mind that the pegs should be spaced at least 5" apart. Four pegs can be made from a 4" length of 1x6.

## CUTTING LIST

Key	Pcs.	Part	Size
A	1	2-3/4"-wide backboard cut to desired length (pegs are spaced 5" apart)	3/4" thick
B	4	Peg blanks	9/16"x1"x3-1/2"

## WOOD FINISHING PRODUCTS

### Recommended Finish

- Prep: Minwax® Pre-Stain Wood Conditioner
- Stain/ Finish: Minwax® PolyShades® Honey Pine (or any color you prefer) Satin or Gloss

### Alternate Finish

- Prep: Minwax® Pre-Stain Wood Conditioner
- Stain: Minwax® Gel Stain Antique Maple (or your choice of Gel Stain colors)
- Finish: Minwax® Wipe-On Poly Satin or Gloss

### Two-Tone Finish

- Prep: Minwax® Water Based Pre-Stain Wood Conditioner
- Stain:
- Rack— Minwax® Water Based Wood Stain Deep Ocean (or a Minwax® Water-Based Wood Stain of your choice, available in 50 custom-mixed colors and a White Wash Pickling Stain.)
- Pegs— Minwax® Water Based Wood Stain Harvest Grain (or a Minwax® Water-Based Wood Stain of your choice, available in 50 custom-mixed colors and a White Wash Pickling Stain.)
- Finish: Minwax® Polycrylic® Protective Finish Satin

## BEFORE YOU BEGIN

Good craftsmanship begins and ends with good work habits, so make the following steps part of your routine workshop practice. If you have any doubts or questions about how to proceed with a project, always discuss them with your shop instructor.

- Carefully and fully review plans and instructions before putting a tool to the project lumber.
- Work sensibly and safely. Wear safety goggles when doing work that creates flying chips and sawdust; wear the appropriate respirator whenever making sawdust or working with thinners or other solvents.
- At the end of every work session, clean up your shop area and put away all portable tools.

## CUTTING AND ASSEMBLY PROCEDURE

1. Using the measurements shown in Fig. B, make a template of the peg's profile on a piece of cardboard. Cut the peg blanks to the dimensions shown and transfer the profile onto both sides of a blank. Orient the grain so it runs roughly parallel to the bottom edge of the blank.

2. The only tool you need for whittling is a knife. Choose one that's comfortable; a big handle can give you more control. Make sure the blade is sharp so that you'll be able to make controlled cuts that are clean and smooth. Always wear a woodcarver's glove and a leather thumb guard to protect yourself.

**Woodworker's Tip:** Practice on an extra blank. Whittling is like peeling a potato. You hold the piece of wood in your free hand, position the thumb of your whittling hand against the end of it, and draw the knife blade through the wood toward your thumb. Make deliberate, shallow cuts, applying just enough pressure to let the knife do its job. Don't make too deep a cut and don't force the knife. That knife is sharp!

You'll be able to tell which way the grain runs by how the knife cuts. Cutting with the grain is smooth and easy, and so is cutting across the grain, as long as you cut from the outer edges toward the center. However, cutting against the grain is likely to result in slips, tear-out and a rough result. When this happens, just turn the piece around so you can cut with the grain. Whittling is so easy that with just a little practice it will become second nature.

3. Extend the shoulder lines of the peg's head and tail across the top of the blank, then cut squarely along the lines to establish the shoulders. Remove the waste above the tenon with a backsaw. If you're not whittling the pegs, set up the scrollsaw and proceed with the cutting. You can form the rounded shapes with a stationary belt sander and a drum sander.

4. If you are whittling, round the back end of the tenon blank with short, paring cuts until it just starts to fit a 1/2" test hole drilled in a scrap piece. Apply a little pressure and spin it to slightly crush the fibers of the unfinished part of the tenon. Remove the peg and pare the rest of the tenon to this mark. Test and pare as necessary for a snug fit.

5. Create the convex curve of the head by making shallow, flat cuts across the end grain. Work down from the top and up from the bottom toward the middle.

6. Cradle the blank in one hand and use a potato-peeling motion. Draw the knife through the wood to the stop cut at the shoulder. This is where a sharp, stiff blade is at its best. Work down by alternately chamfering (deeply beveling) the outer edges, then removing the center ridge until you reach the pattern lines. Finish the peg by chamfering all outer edges.

7. Cut the 2-3/4"-wide backboard to the desired length; you can make it as long as you want, keeping in mind that the holes for the pegs should be spaced at least 5" apart (Fig. A). Chamfer the edges with a block plane and then drill 1/2" holes centered 1-5/8" from the top edge. Drill holes between the outer two pegs on each end for attaching to a wall. Check the size of your fastener to determine the size of these holes. Sand the backboard smooth.

8. To install the pegs, apply glue around the insides of the holes with a slim wooden stick, then twist the pegs into place, making sure that their flat sides are perpendicular to the long dimension of the backboard. You can check this with a small square.

## STAINING AND FINISHING

**Woodworker's Tip:** Though you may be tempted to cut short your sanding, preparation and application, don't do it. These tasks are very important steps in obtaining a high-quality finish. Remember, it is the finish, just as much as the fit and smoothness of the parts that will determine how people judge your craftsmanship. To ensure an excellent result, follow the steps below and also the instructions the manufacturers put on their products.

### FINISHING TIPS

- Test the stains and finishes you are planning to use on scraps of wood. On the back of the scrap, mark the stain/finish combination and the type of wood. Allow all samples to dry thoroughly before making your final finish selection. Save your samples for quick reference on future projects.
- All stains and finishes must be allowed to dry thoroughly between coats. Remember that drying times can vary due to humidity and other climatic conditions.
- If you have some leftover stain or finish, wipe the can rim so that stain or finish in the rim won't dry out and prevent the lid from forming a tight seal.
- Brushes used for oil-based finishes must be cleaned with mineral spirits; for water-based products, such as Minwax® Water-Based Wood Stains or Minwax® Polycrylic® Protective Finish, clean brushes with warm water and soap.

9. Before staining and finishing, finish-sand all surfaces and ease all the edges. Wipe the piece down with a cloth dampened with mineral spirits. If you're building the rack with a softwood, such as pine, or a porous hardwood, like maple, you'll need to prepare it for staining with a coat of Minwax® Pre-Stain Wood Conditioner when using an oil-based stain or with Minwax® Water-Based Pre-Stain Wood Conditioner

if using a water-based stain. Applying the conditioner will help to ensure even absorption of stain and prevent blotchiness that can occur with some soft or porous woods. Simply brush the conditioner over all the wood and allow it to penetrate for 5 to 15 minutes. Then remove excess conditioner with a clean, dry cloth.

#### Recommended Finish:

**10.** After sanding the piece with 220-grit sandpaper using with-the-grain strokes, thoroughly wipe off with a clean, lint-free cloth. Apply Minwax® PolyShades® following the directions on the can. Use a natural bristle brush intended for use with polyurethane. Stir the can contents thoroughly before starting and periodically repeat the stirring during your work session. Allow the first coat to dry overnight.

**11.** Once PolyShades® is completely dry, lightly go over all surfaces with fine (000) steel wool or 220-grit sandpaper using with-the-grain strokes. Thoroughly wipe off all surfaces with a soft cloth. Apply a second coat of Polyshades® and set the piece aside to dry overnight.

**12.** If a third coat is desired for more color or increased protection, repeat step 11. Allow the finish to cure for several days before installing the rack.

#### Alternate Finish:

**13.** Prepare the wood as you did in step 9.

**14.** Apply the Minwax® Gel Stain using a natural bristle brush or a clean, lint-free cloth. Allow the Gel Stain to set for about 5 to 10 minutes, then wipe off any excess. Allow the stain to dry for 24 hours before applying the protective clear finish.

**Woodworker's Tip:** *When wiping off stain, make certain that your last wipe with the cloth goes with the grain of the wood.*

**15.** Apply Minwax® Wipe-On Poly following the directions on the can. Use a clean, soft, lint-free cotton cloth. Allow the first coat to dry overnight.

**16.** The next day, sand all surfaces lightly with 220-grit sandpaper using with-the-grain strokes. Thoroughly wipe off all surfaces with a soft cloth. Apply a second coat of Wipe-On Poly and set the piece aside to dry overnight.

**17.** The next day, sand all surfaces lightly with 220-grit sandpaper. Thoroughly wipe off the piece with a soft cloth and apply the third and final coat of Wipe-On Poly. Allow the finish to cure for several days before installing the rack.

#### Two-Tone Finish:

**18.** Before applying Minwax® Water Based Wood Stain to a hardwood or softwood, apply Minwax® Water Based Pre-Stain Wood Conditioner following the directions on the can. After 1 to 5 minutes, wipe off all excess conditioner using a clean, lint-free cloth. Wait 15 to 30 minutes, then use 220-grit sandpaper to sand off any “whiskers” raised by the conditioner. Proceed to the staining within 2 hours.

**19.** Apply Minwax® Water-Based Wood Stain using either a nylon/polyester brush or a soft cloth. Allow stain to penetrate no longer than 3 minutes. While stain is still wet, wipe off excess with a clean cloth that's been lightly dampened with stain using with-the-grain strokes. If a second coat is desired, allow the piece to dry for 2 hours before applying stain. Let the piece dry thoroughly before applying the protective clear finish.

**Woodworker's Tip:** *Minwax® Water Based Wood Stain is available in 50 custom-mixed colors and a White Wash Pickling Stain. This means that you are not limited to just traditional wood tones (pine, oak, walnut, etc.). Instead, you can pick and apply a color to complement the décor of the room in which the peg rack will hang. For this reason, make sure you look over all of the Minwax® stain color charts before making your final selection.*

**20.** After allowing the piece to dry thoroughly, apply Minwax® Polycrylic® Protective Finish following the directions on the can. Stir the contents of the can thoroughly before starting and periodically repeat the stirring during your work session.

**21.** Using a nylon/polyester brush, work a small area at a time to maintain a wet edge when applying the first coat. Work quickly and make the final strokes in each newly finished section using with-the-grain brushstrokes.

**22.** Allow the finish to dry a minimum of 2 hours. Then sand lightly with 220-grit sandpaper. Thoroughly wipe off all surfaces with a clean, soft cloth.

**23.** Repeat steps 20 and 21 to apply the second coat. Allow the finish to cure for about 1 to 2 days before installing the rack.

#### PRODUCT SAFETY

For your safety and the safety of those you work with, always read the safety warnings, which manufacturers print on their labels, and follow them to the letter. Typical safety advice and instructions will contain information such as the following:

**WARNING!** Removal of old paint by sanding, scraping or other means may generate dust or fumes that contain lead. Exposure to lead dust or fumes may cause brain damage or other adverse health effects, especially in children or pregnant women. Controlling exposure to lead or other hazardous substances requires the use of proper protective equipment, such as properly fitted respirator (NIOSH approved) and proper containment and cleanup. For more information, call the National Lead Information Center at 1-800-424-LEAD (in US) or contact your local health authority.

**When using oil-based wood finishing products:**

**CAUTIONS: CONTAINS ALIPHATIC HYDROCARBONS. Contents are COMBUSTIBLE.** Keep away from heat and open flame. **VAPOR HARMFUL.** Use only with adequate ventilation. To avoid overexposure, open windows and doors or use other means to ensure fresh air entry during application and drying. If you experience eye watering, headaches, or dizziness, increase fresh air, or wear respiratory protection (NIOSH approved) or leave the area. Avoid contact with eyes and skin. Wash hands after using. Keep container closed when not in use. Do not transfer contents to other containers for storage.

**FIRST AID:** In case of eye contact, flush thoroughly with large amounts of water for 15 minutes and get medical attention. For skin contact, wash thoroughly with soap and water. In case of respiratory difficulty, provide fresh air and call physician. If swallowed, call Poison Control Center, hospital emergency room, or physician immediately.

**NOTICE:** Reports have associated repeated and prolonged occupational exposure to solvents with permanent brain and nervous system damage. Intentional misuse by deliberately concentrating and inhaling contents may be harmful or fatal.

**WARNING:** This product contains a chemical known to the State of California to cause cancer and birth defects or other reproductive harm.

**DO NOT TAKE INTERNALLY. KEEP OUT OF REACH OF CHILDREN.**

**When using water-based wood finishing products:**

**CAUTIONS:** Use Only With Adequate Ventilation. To avoid overexposure, open windows and doors or use other means to ensure fresh air entry during application and drying. If you experience eye watering, headaches, or dizziness, increase fresh air, or wear respiratory protection (NIOSH approved) or leave the area. Avoid contact with eyes and skin. Wash hands after using. Keep container closed when not in use. Do not transfer contents to other containers for storage. **FIRST AID:** In case of eye contact, flush thoroughly with large amounts of water. Get medical attention if irritation persists. If swallowed, get medical attention immediately.

**WARNING:** Contains Alkyl propanols, ethylene glycol, n-methyl pyrrolidone. **VAPOR HARMFUL.** Use only with adequate ventilation. To avoid overexposure, open windows and doors or use other means to ensure fresh air entry during application and drying. If you experience eye watering, headaches, or dizziness, increase fresh air, or wear respiratory protection (NIOSH approved) or leave the area. Avoid contact with eyes and skin. Wash hands after using. Keep container closed when not in use. Do not transfer contents to other containers for storage.

**DO NOT TAKE INTERNALLY.**

**FIRST AID:** In case of eye contact, flush thoroughly with large amounts of water for 15 minutes and get medical attention. For skin contact, wash thoroughly with soap and water. In case of respiratory difficulty, provide fresh air and call physician. If swallowed, call Poison Control Center, hospital emergency room, or physician immediately.

**DELAYED EFFECTS FROM LONG-TERM OVEREXPOSURE.**

Contains solvents which can cause permanent brain and nervous system damage. Intentional misuse by deliberately concentrating and inhaling contents may be harmful or fatal.

**WARNING:** This product contains a chemical known to the State of California to cause cancer and birth defects or other reproductive harm.

**KEEP OUT OF REACH OF CHILDREN.**

**SAFE DISPOSAL OF RAGS AND WASTE.**

Please be mindful of the safe way to dispose of rags and other waste. Rags, steel wool and other waste products soaked with oil finishes or solvents may spontaneously catch fire if improperly discarded. Place rags, steel wool and other waste immediately after use in a water-filled metal container. Tightly seal and dispose of the waste materials in accordance with local trash removal regulations. Be sure to keep the waste out of reach of children.

This project was adapted with permission from *American Woodworker* magazine, Home Services Publications, Inc., an affiliate of Reader's Digest Association, Inc., Suite 700, 2915 Commers Drive, Eagan, MN 55121. ©Copyright 2002. All rights reserved. For subscriptions call toll-free: 1-800-666-3111.

**AMERICAN  
WOODWORKER**

**FIG A. WHITTLED PEG RACK**

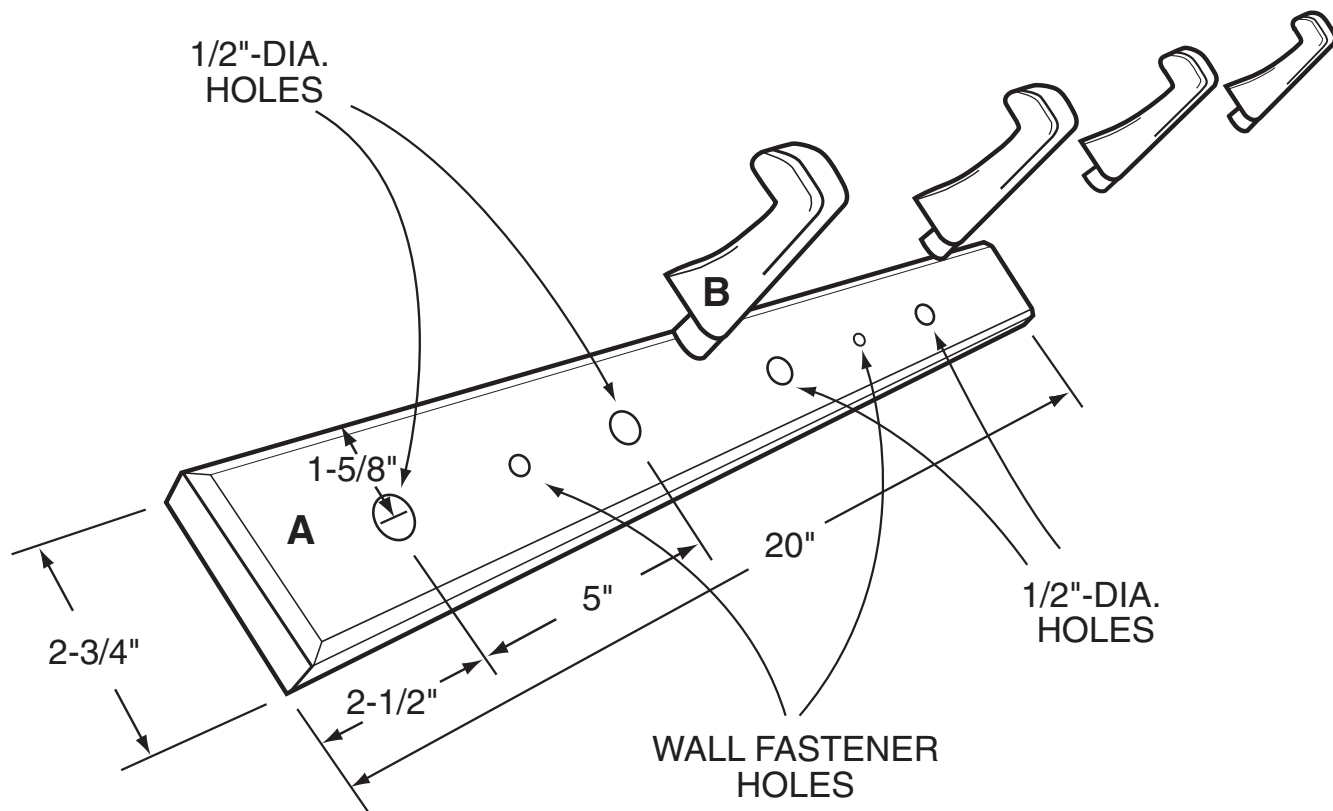

**FIG B. PEG TEMPLATE**

